

Warm Electromagnetic Forming of AZ31B Magnesium Alloy Sheet

I. Ulacia¹, A. Arroyo², I. Eguia², I. Hurtado¹, M.A. Gutiérrez²

¹ Mondragon Goi Eskola Politeknikoa, Mondragon Unibertsitatea, Mondragon, Spain

² Labein-Tecnalia Research Center, Derio, Spain

- Introduction and motivation

- Electromagnetic forming experiments
 - EMF drawing

 - EMF bending

- Conclusions and ongoing work

There is a clear tendency for **weight reduction** in automotive and aeronautic industries.



“Cars on a diet”

The use of magnesium parts is expected to increase (e.g. Usamp 2007)



Mg alloys

	Al	Mg	Steel	Ti
ρ	2.8	1.74	7.83	4.5
E	70	45	210	110
R_m	150-680	100-380	300-1200	910-1190
$R_m/\rho^{(1)}$	54-243	57-218	38-153	202-264
$E/\rho^{(2)}$	25.0	25.9	26.8	24.4
$\sqrt{R_m}/\rho^{(3)}$	9.3	11.2	4.4	7.7
$\sqrt[3]{E}/\rho^{(4)}$	14.7	20.4	7.6	10.6

[Kleiner et al. 2003]

Strategies to increase formability:

Increasing Temperature: Warm Forming

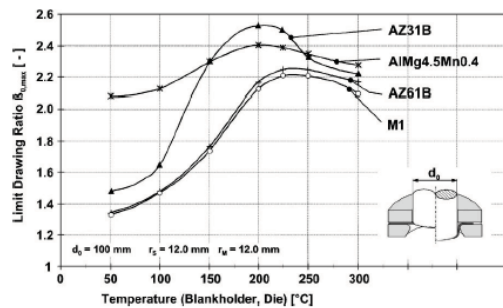

[Doege et al. 2001]

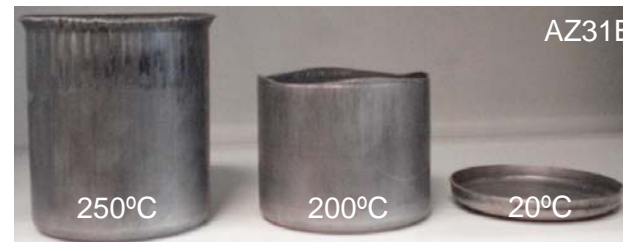

[Ulacia et al. 2008]

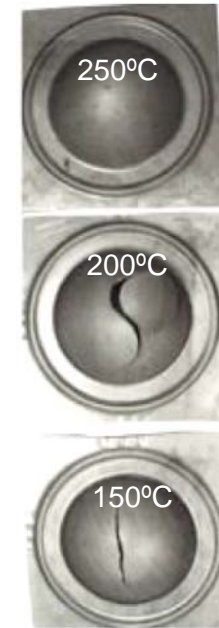

Increasing Strain Rate (EMF, EHF and explosive forming)

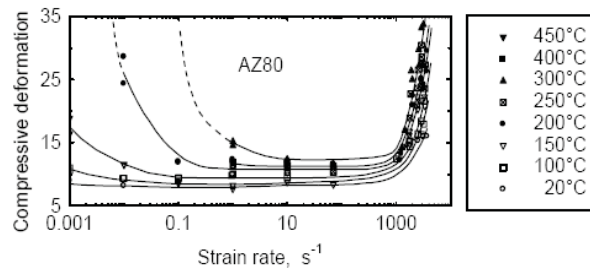

[El-Magd et al. 2004]

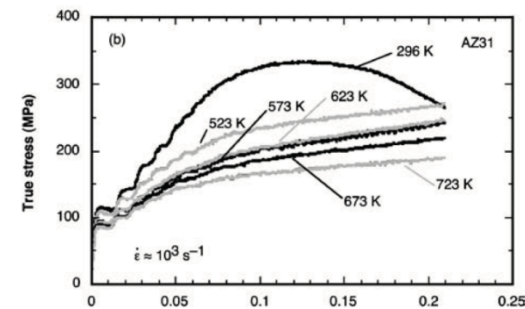

[Ishikawa et al. 05]

Previous work in EMF of Mg alloys:

Tube

TU Berlin, Germany
[Uhlmann *et al.* 2004]

A **tool** for combining Inductive Heating and Magnetic Forming was shown.

No deformed parts or values were shown

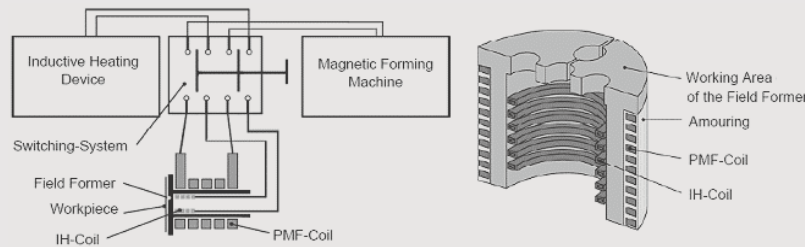

IUL Dortmund, Germany
[Psyk *et al.* 2006]

Suitability of different **extruded Mg tubes** for EMF was characterised

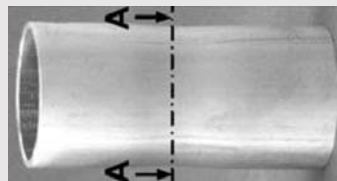

Sheets

VTT and Helsinki University, Finland
[Revueña *et al.* 2007]

Increase of formability was reported for AZ31B, although deformation values were not shown



Labein and Mondragon Univ., Spain
[Ulacia *et al.* 2008]

Increase of formability was measured for AZ31B at Room Temp

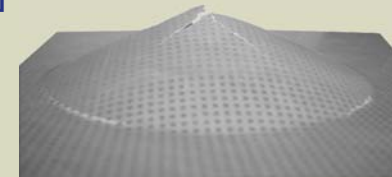

AIST, Japan
[Murakoshi *et al.* 2008]

EMF at different temp.

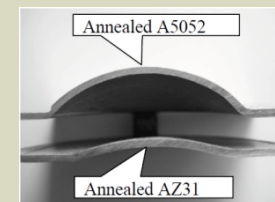

Current research:

Aim: Evaluate the effect of temperature on the electromagnetic forming of Mg AZ31 sheets

AZ31B (commercial). 1 mm thickness. GS=10 μ m

Element	Zn	Al	Si	Cu	Mn	Fe	Ni	Ca	Sn	Others
wt%	0.96	2.7	0.01	≤0.01	0.21	0.002	≤0.001	≤0.01	0.00	≤0.30

Increasing temperature

Decrease of electrical conductivity 

Decrease of yield strength 

Increase of active def. mechanisms 

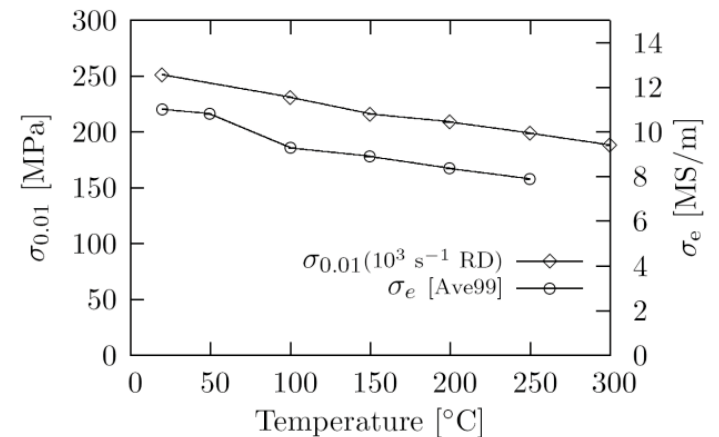
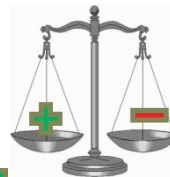

EMF at different temperatures:

Machine: Maxwell Magneform at *Labein-Tecnalia*

- Capacitor bank: 60kJ (1800 μ f – 8.66 kV)
- 40 Tn Hydraulic Press
- Coils & dies:

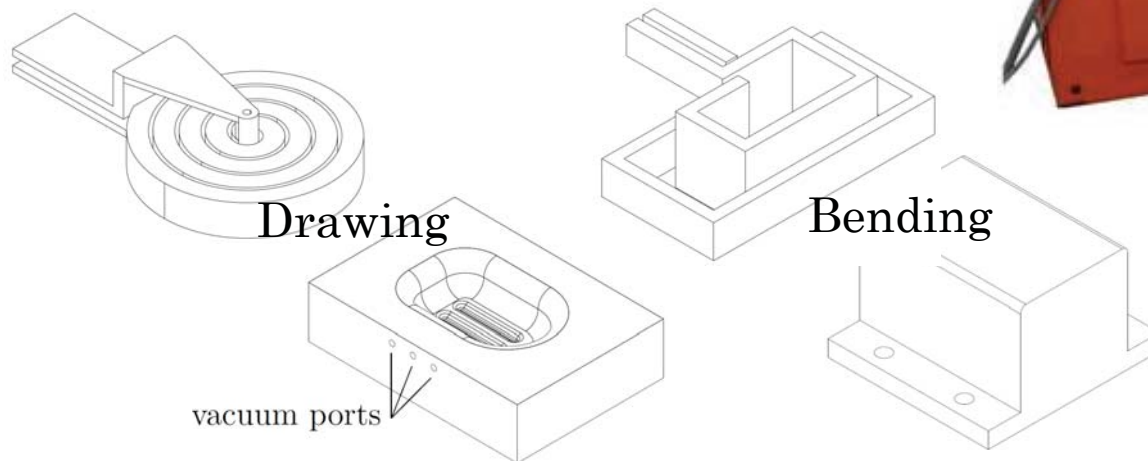

Test conditions:

- **Temperatures:** R.T., 100°C, 150°C, 200°C, 250°C
- **Discharged Energies:**
 - 6 kJ - 15 kJ (Drawing)
 - 1 kJ – 6 kJ (Bending)

EMF at different temperatures:

Heating Strategy: Heating outside the forming position

Step 1. Heating: Temperature was controlled with thermocouples

Step 2. Automatic Transfer: Temp drop measured (Cooling curves for each Temp)

Step 3. Closing and EMF discharge:
Time for discharging measured → Initial Temp.

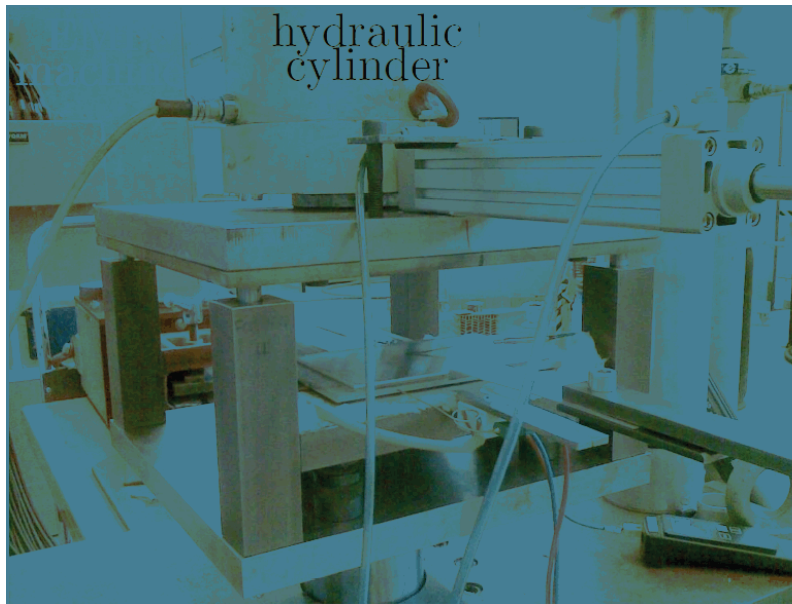
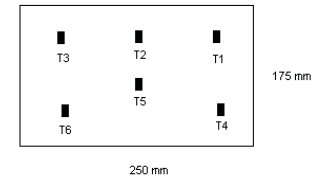

Cooling curve for 250°C

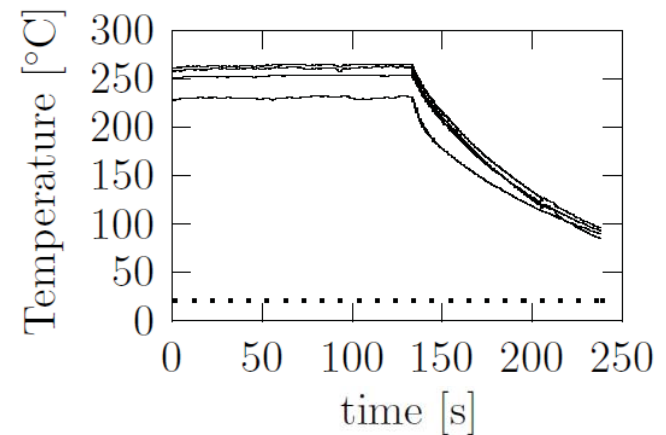

EMF Drawing



- Increasing the temperature
- Decreases h_{max}
 - More energy

EMF Bending

Room temperature

Energy for impact?

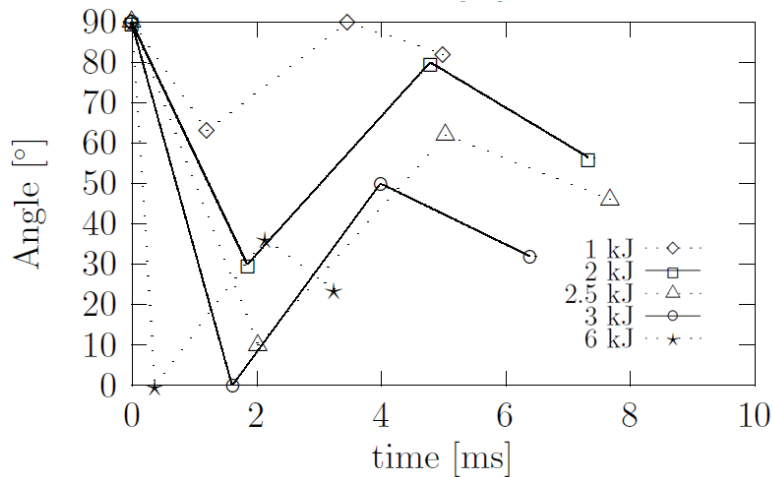
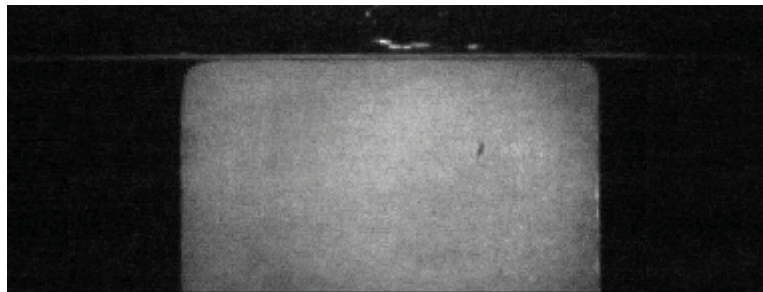

	Impact/Max.Def.	Springback	Final shape
1 kJ	t ≈ 1.2 ms	t ≈ 3.46 ms	t ≥ 5 ms
2 kJ	t ≈ 1.86 ms	t ≈ 4.8 ms	t ≥ 7.33 ms
2.5 kJ	t ≈ 2.026 ms	t ≈ 5.04 ms	t ≥ 7.68 ms
3 kJ	t ≈ 1.626 ms	t ≈ 4 ms	t ≥ 6.4 ms
6 kJ	t ≈ 0.373 ms	t ≈ 2.13 ms	t ≥ 3.25 ms

- Non-symmetrical deformation (coil)
- Impact in 2.5-3 kJ
- Decrease of springback with increasing energy
- Higher plastic deformation
- High velocity impact

EMF Bending

Different temperatures

For a given energy, if:

Temperature \uparrow (Elect. Conductivity \downarrow) \rightarrow Forces (Acceleration) \downarrow \rightarrow Impact vel. \downarrow

Then, from the previous results we should expect that:

The final springback will increase with temperature.

EMF Bending

Different temperatures

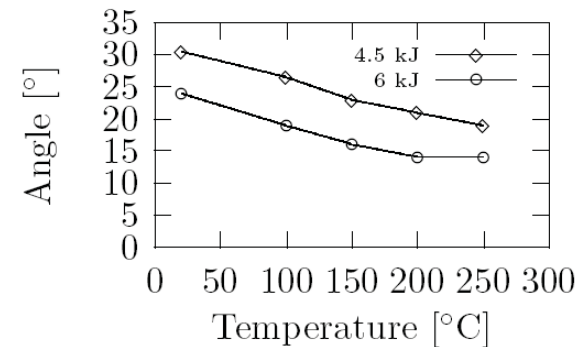
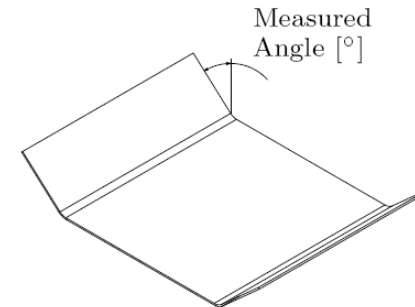
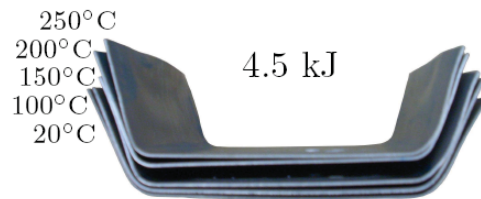

*Non homogeneous deformation in the whole flange

Increasing temperature: final angle is closer to the **target angle**

→ Reduction of springback due to decrease of yield strength with temperature

Concluding remarks:

Warm EMF is studied: **Higher deformation** values could be obtained increasing **temperature**

→ It could be suitable to form **complex geometries** in Mg parts

Springback behavior of magnesium sheet at high strain rates was studied (EMF bending experiments). It was shown that:

- Increasing the discharged energy the springback decreases
- Increasing temperature also decreases the springback

It is shown that temperature has different effect depending on the EMF operation:

- The decrease of electrical conductivity is important in drawing operations
- The decrease of yield stress is more important in bending

Material Characterization at high strain rate biaxial loading:

- Microstructure and texture analysis (EBSD & Neutron diff.)

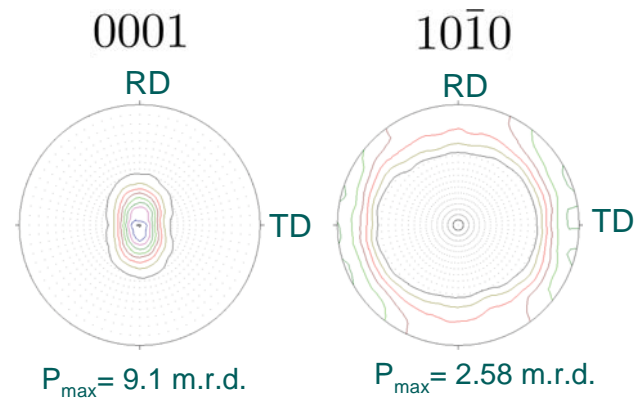
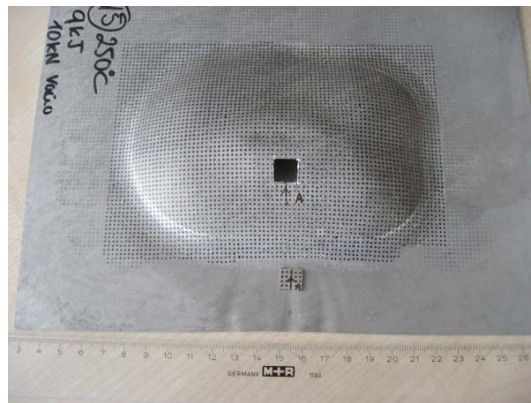

- Compare with uniaxial results

EMF of other Mg alloys (e.g. ZE10)

- Weaker initial texture



Warm Electromagnetic Forming of AZ31B Magnesium Alloy Sheet

Thank you for your attention!



Dr. Ibai Ulacia

Mechanical and Manufacturing Department
Mondragon Goi Eskola Politeknikoa
Mondragon Unibertsitatea
iulacia@eps.mondragon.edu