

# 4<sup>th</sup> International Conference on High Speed Forming

March 9-10, 2010

Columbus, Ohio 43210



## MATHEMATICAL MODELING OF AN ELECTROMAGNETIC FORMING SYSTEM WITH FLAT SPIRAL COILS AS ACTUATOR

***Evandro Paese<sup>1</sup>, Martin Geier<sup>1</sup>, Joyson L. Pacheco<sup>1</sup>, Roberto P. Homrich<sup>2</sup>***

*<sup>1</sup>Grupo de Projeto, Fabricação e Automação Industrial – PROMEC – Universidade Federal do Rio Grande do Sul.*

*<sup>2</sup>Laboratório de Máquinas Elétricas, Acionamentos e Energia– DELET – Universidade Federal do Rio Grande do Sul.*

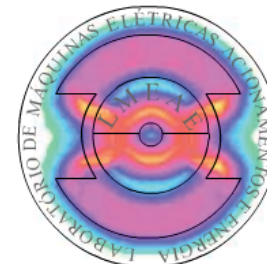

1. Introduction and motivation
2. Description of the electromagnetic problem
3. Basic description of the mathematical model
4. Biot-Savart Law for calculation of the magnetic field produced by a circular loop at any point in space
5. Calculation of the electromagnetic force
5. Parameters of the Electromagnetic Forming System
6. Results and discussion
7. Conclusions
8. Future Works
9. Acknowledgements
10. References

## 1. Introduction and Motivation

- ❑ Several studies involve specific situations for forming of tubular parts by solenoid coils, while few studies have analyzed sheet metal forming by flat actuator coils[1];
  
- ❑ This work presents a mathematical model of the electromagnetic forming system and numerical methods for solving a specific problem at the initial instant *before plastic deformation* of circular metal sheets by using a flat spiral actuator coil;
  
- ❑ These method discretizes the flat spiral coil and the blank in elementary segments of conductor rings, allowing the system to be represented by a set of differential equations, thus the calculation of the electromagnetic coupling between actuator coil and workpiece.

## 1. Introduction and Motivation

- The electromagnetic problem is formulated in terms of the magnetic field and the electrical problem as a circuit with mutual inductances.
  
- Experimental results are also presented for different thicknesses of aluminum plates and the results are compared with numeric solution of mathematical modeled in software Matlab.

## 2. Description of the Electromagnetic Problem

A schematic model of the system analyzed is presented below which shows a circular clamped metal sheet placed above a flat spiral coil connected to a charged capacitor bank.

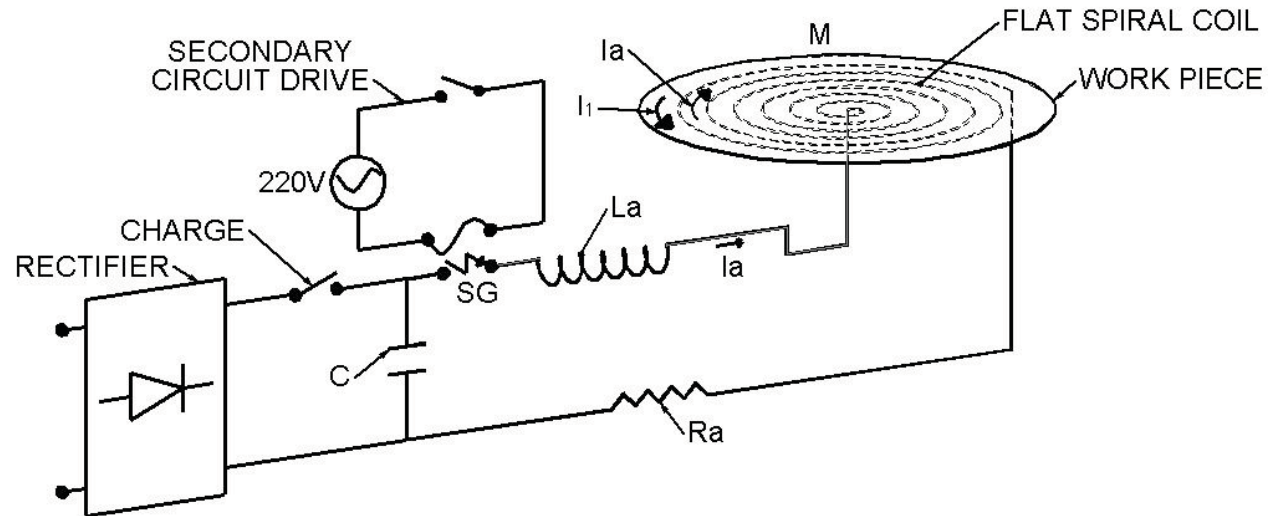

The mechanical and electromagnetic phenomena of the process are strongly interrelated, and the deformation of the workpiece affects the magnetic field and, consequently, the Lorentz forces developed.

An approximate but a more realizable approach is to treat the process as a loosely coupled problem, disregarding the influence of deformation of the workpiece on the evolution of the magnetic field, and then apply the generated forces by the electromagnetic field in the mechanical problem [2].

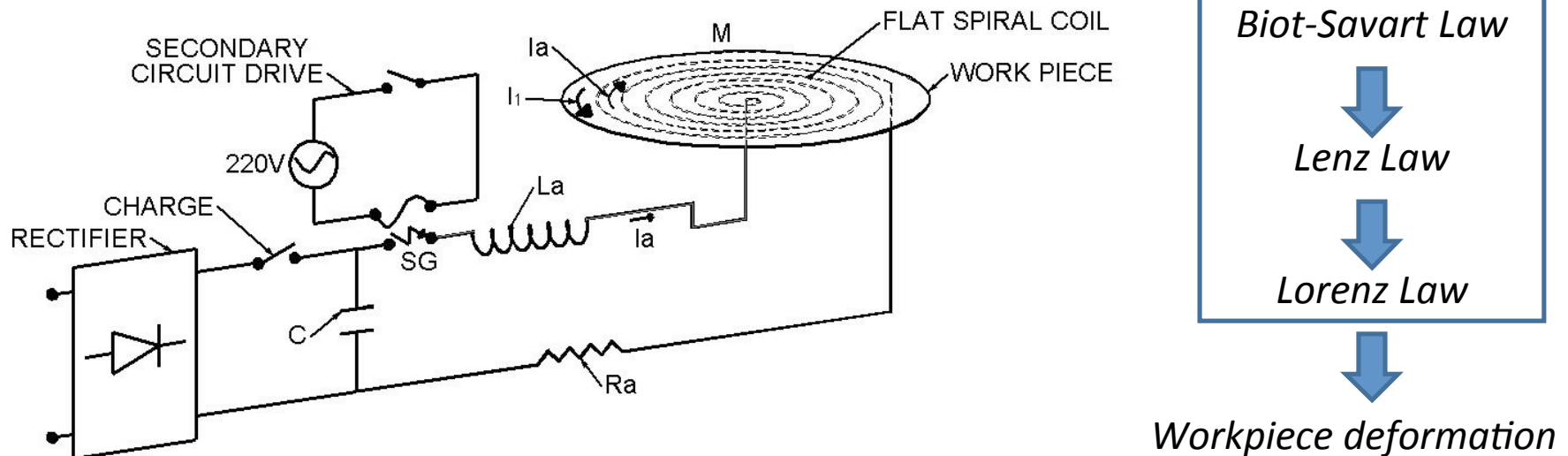

## 2. Description of the problem: an analogy to electrical circuit

The transient electromagnetic problem can be separated in a primary RLC circuit coupled with secondary RL circuit [4], [5]. Whereas the discharge of the capacitor in the primary circuit, we can write the differential equation:

$$\frac{d}{dt} \left( L_a \cdot I_a + M \cdot I_1 \right) + R_a \cdot I_a + V_c = 0 \quad (1)$$

Where  $L_a$ ,  $R_a$  and  $V_c$  are the self inductance, resistance of actuator coil and electric potential in capacitor bank.  $M$  is the mutual inductance between the actuator coil and workpiece.  $I_a$  and  $I_1$  is the discharge current in actuator coil and the induced current in workpiece.

$$\frac{d}{dt} \left( L_1 \cdot I_1 + M \cdot I_a \right) + R_1 \cdot I_1 = 0 \quad (2)$$

Where  $L_1$  and  $R_1$  are the self inductance and resistance of workpiece.

### 3. Basic description of the mathematical model

These method discretizes the flat spiral coil and the blank in elementary segments of conductor rings in an axisymmetric configuration (in this work: 6 spaced rings for the coil and 12 consecutive rings for the blank).

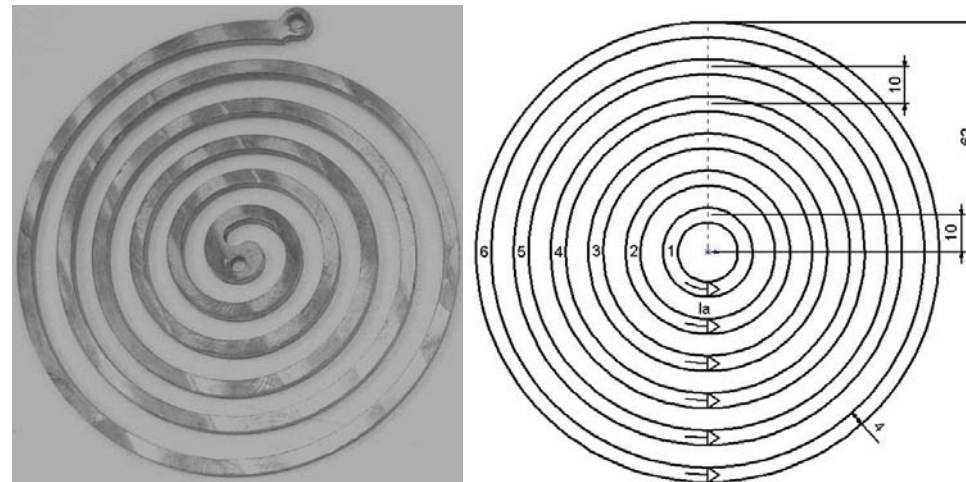

For the initial instant before plastic deformation occurs, the following set of differential equations is valid:

$$\begin{bmatrix} 0 & 1 & 0 & 0 & 0 \\ 1 & R_a & 0 & 0 & 0 \\ 0 & 0 & R_1 & 0 & 0 \\ 0 & 0 & 0 & R_2 & 0 \\ 0 & 0 & 0 & 0 & R_n \end{bmatrix} \cdot \begin{bmatrix} Vc \\ I_a \\ I_1 \\ I_2 \\ I_n \end{bmatrix} + \begin{bmatrix} -C & 0 & 0 & 0 & 0 \\ 0 & L_a & M_{a1} & M_{a2} & M_{an} \\ 0 & M_{1a} & L_1 & M_{12} & M_{1n} \\ 0 & M_{2a} & M_{21} & L_2 & M_{2n} \\ 0 & M_{na} & M_{n1} & M_{n2} & L_n \end{bmatrix} \cdot \begin{bmatrix} \frac{dVc}{dt} \\ \frac{dI_a}{dt} \\ \frac{dI_1}{dt} \\ \frac{dI_2}{dt} \\ \frac{dI_n}{dt} \end{bmatrix} = \begin{bmatrix} 0 \\ 0 \\ 0 \\ 0 \\ 0 \end{bmatrix} \quad (3)$$

This system of differential equations of first and second order is solved by a resident function of the software *Matlab*® after the discretization of the workpiece in a finite number of conductive turns.

## 4. Magnetic Field: Biot-Savart Law

Law of Biot-Savart for Calculation of the Magnetic Field Produced by a Circular Loop at any Point in Space.

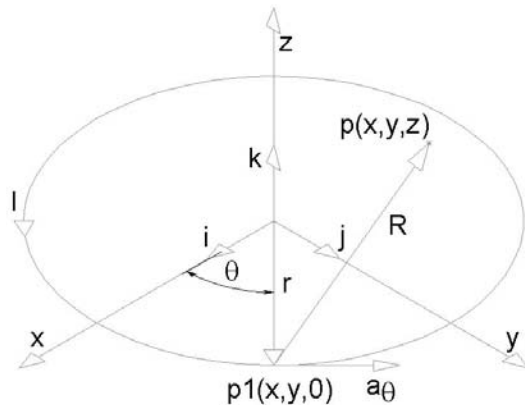

$$B_x = \frac{\mu_0 \cdot I \cdot r \cdot z}{4 \cdot \pi} \int_0^{2\pi} \frac{\cos \theta}{\left[ x^2 + y^2 + z^2 + r^2 - 2 \cdot r \cdot (x \cdot \cos \theta + y \cdot \sin \theta) \right]^{3/2}} \cdot d\theta \quad (4)$$

$$B_y = \frac{\mu_0 \cdot I \cdot r \cdot z}{4 \cdot \pi} \int_0^{2\pi} \frac{\sin \theta}{\left[ x^2 + y^2 + z^2 + r^2 - 2 \cdot r \cdot (x \cdot \cos \theta + y \cdot \sin \theta) \right]^{3/2}} \cdot d\theta \quad (5)$$

$$B_z = \frac{\mu_0 \cdot I \cdot r}{4 \cdot \pi} \int_0^{2\pi} \frac{r - y \cdot \sin \theta - x \cdot \cos \theta}{\left[ x^2 + y^2 + z^2 + r^2 - 2 \cdot r \cdot (x \cdot \cos \theta + y \cdot \sin \theta) \right]^{3/2}} \cdot d\theta \quad (6)$$

$$B_r = \frac{\mu_0 \cdot I \cdot z \cdot r}{4 \cdot \pi} \int_0^{2\pi} \frac{\cos(\theta - \alpha)}{\left[ x^2 + y^2 + z^2 + r^2 - 2 \cdot r \cdot (x \cdot \cos \theta + y \cdot \sin \theta) \right]^{3/2}} \cdot d\theta \quad (7)$$

$$B_\alpha = \frac{\mu_0 \cdot I \cdot z \cdot r}{4 \cdot \pi} \int_0^{2\pi} \frac{\sin(\theta - \alpha)}{\left[ x^2 + y^2 + z^2 + r^2 - 2 \cdot r \cdot (x \cdot \cos \theta + y \cdot \sin \theta) \right]^{3/2}} \cdot d\theta \quad (8)$$

$$\alpha = \arctg\left(\frac{By}{Bx}\right) = \arctg\left(\frac{y}{x}\right) \quad (10)$$

$$B_z = \frac{\mu_0 \cdot I \cdot r}{4 \cdot \pi} \int_0^{2\pi} \frac{r - y \cdot \sin \theta - x \cdot \cos \theta}{\left[ x^2 + y^2 + z^2 + r^2 - 2 \cdot r \cdot (x \cdot \cos \theta + y \cdot \sin \theta) \right]^{3/2}} \cdot d\theta \quad (9)$$

- Equations (6), (7) and (8) are used to calculate the three components of the vector density of magnetic field B at the point p in cylindrical coordinates.
- These equations can be solved analytically only for points located in the center of the circular geometry and p (0,0,z).
- In this study, resident functions of software Matlab were used to the numerical solution of the above integral equations.

## 4. Magnetic field: radial component

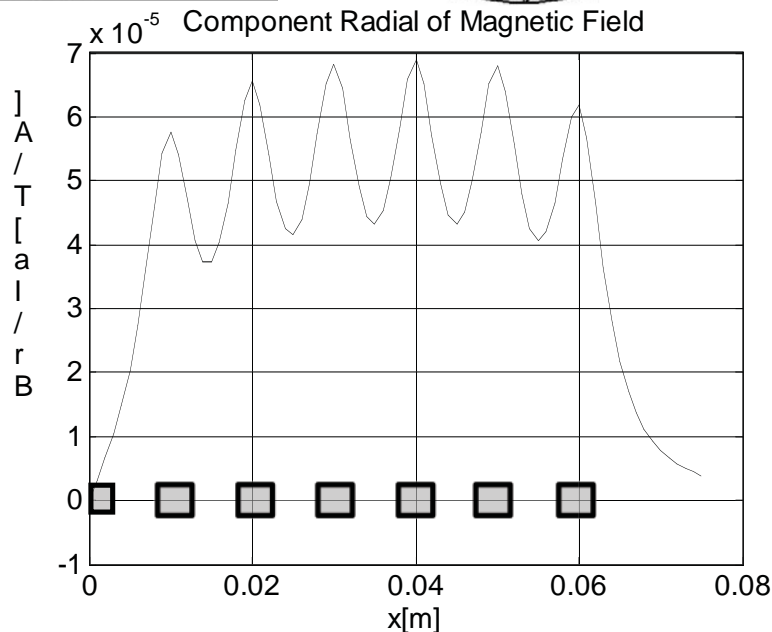
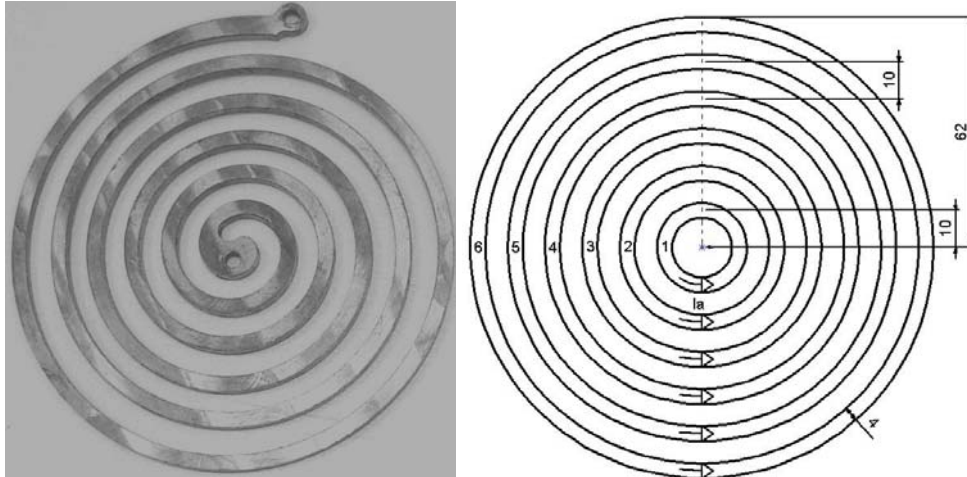

□ Real and simplified models of the flat spiral coil actuator used in this study.

□ Considering the symmetry of the problem these values are the same for any position in relation of the revolution axis z in the center of the spiral coil.

- The workpiece is discretized in 12 coaxial circular elementary conductors (L1, L2...L12), where L1 and L12 are the outer diameter and inner diameter respectively;
- The greater the number of circular conductor elements more accurate is the model but more processing time is needed. The electromagnetic force generated by each circular conductor can be calculated by:

$$F_n = B_r \cdot I_a \cdot I_n \cdot c_n \quad (11)$$

Where  $F_n$ ,  $B_r$ ,  $I_a$ ,  $I_n$ ,  $c_n$  is the force in circular conductor of the workpiece, the magnetic field in radial direction, the discharge current in actuator coil, the induced current in conductor on the workpiece and length (perimeter) of the circular conductor  $n$  of the workpiece

## 6. Parameters of the Electromagnetic Forming System

□ This model was primary used to develop a system of electromagnetic forming of thin metal sheets (blanks) by using a flat spiral coil:

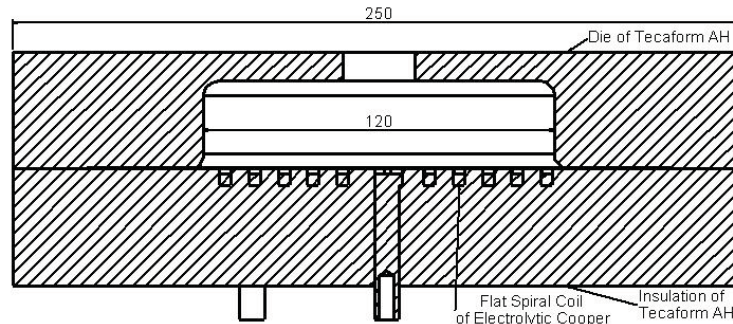
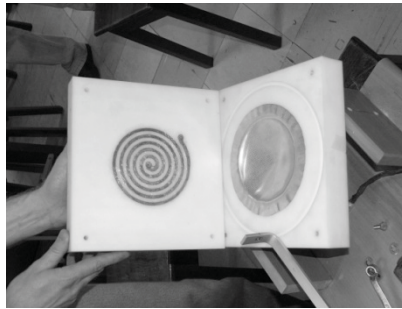

Equipment	Parameter	Value
Actuator Coil of Electrolytic Cooper	Numbers of turns	6
	Diameter biggest turn	120mm
	Pitch	10mm
	Cross section	4 x 4mm
	Self inductance ( $L_a$ )	1.0326 $\mu$ H
	Resistance ( $R_a$ )	1.4m $\Omega$
Capacitor bank	Capacitance	8400 $\mu$ F
	Maximum voltage	900 V
	Maximum energy	3.4kJ
Workpiece	Material	Aluminium AA1100
	Thickness	0.3, 0.5 and 1mm
	Blank diameter	170 mm
	Resistivity	$\Omega$ .mm
	Gap between actuator and metal sheet	1.5 mm

## 7. Results and discussion

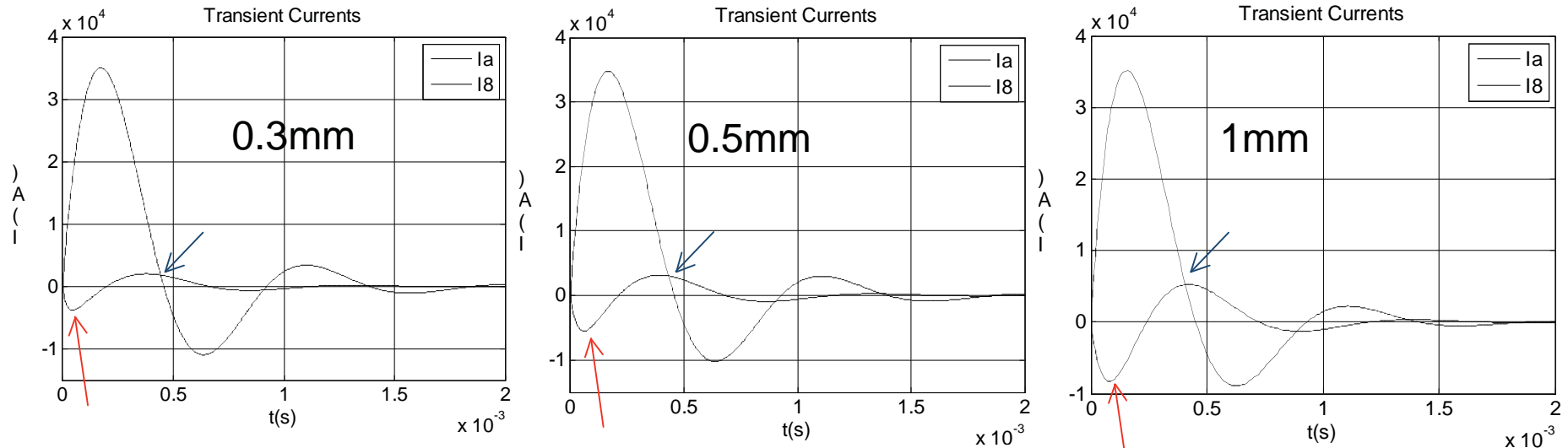

Where,

$I_a$ : current in the actuator coil;

$I_8$ : induced current in the workpiece (for the 8<sup>th</sup> concentric ring);

- ❑ Peak of electric current in the actuator remained almost constant; biggest changes occur in the induced currents (red arrows);
- ❑ It is also observed different phases between the current in the coil and in the workpiece in respect to its thickness (blue arrows);
- ❑ This system behaves as a underdamped RLC circuit and the current in the actuator coil and workpiece are opposites. The first peak of the induced currents are around :  $-0.38\text{kA}$  (0.3 mm),  $-0.55\text{kA}$  (0.5 mm) and  $-0.83\text{kA}$  (1 mm).

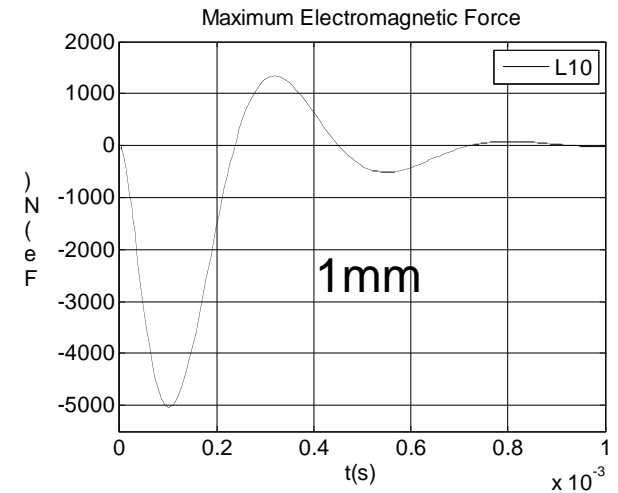
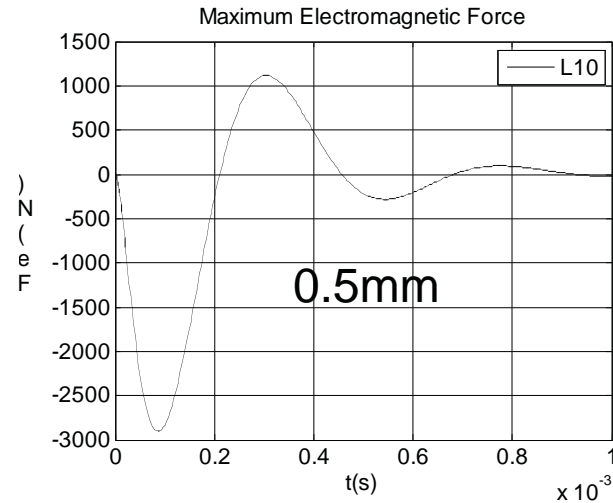
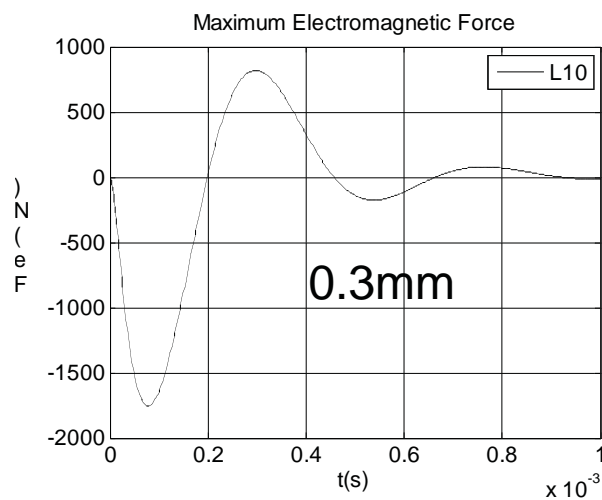

□ In respect to the maximum axial transient electromagnetic force:

The greater the difference phase between the current in the coil actuator and the induced current in the workpiece causes a greater back electromagnetic force (second half wave/ first positive peak) when it's compared with electromagnetic force of repulsion (first half wave/ first negative peak);

## 7. Results and discussion

- Distribution of the repulsive force for axisymmetric problem:

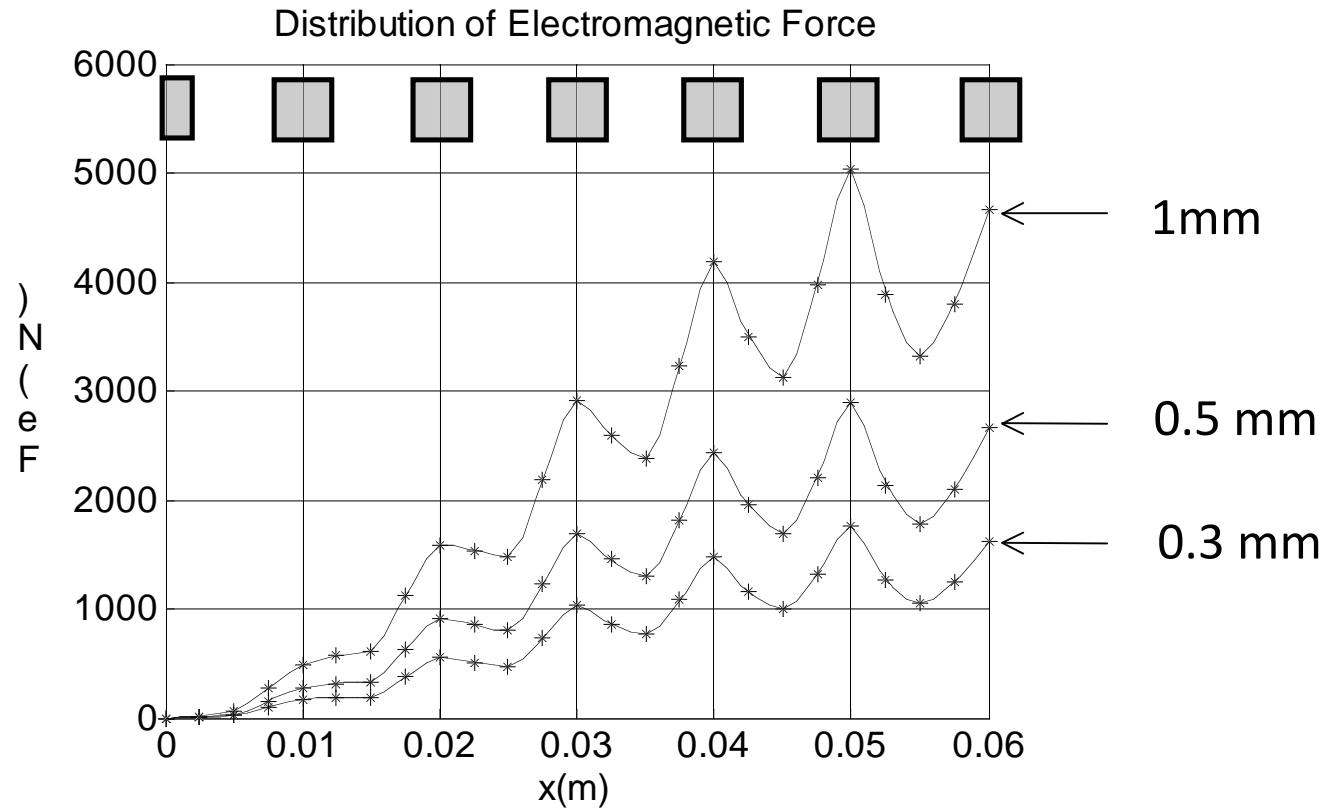

### □ Electromagnetic forming:



0.3mm



0.5mm



1mm

Experimental results show the influence of back electromagnetic force (second half wave) in thinner sheets when it's compared with electromagnetic force of repulsion (first half wave).

## 8. Conclusions

- ✓ In this work it was developed a numerical method which can simulate the electromagnetic forming of metal sheets at the initial instant before plastic deformation. The algorithm was implemented in software Matlab®;
- ✓ It can be observed in practical experiments that the back electromagnetic force in thinner metal sheets prevents the electromagnetic forming with proposed system in this paper;
- ✓ This mathematic model showed satisfactory results when compared with experiments, serving as a tool for design of actuators and electromagnetic processes.
- ✓ In this algorithm the process parameters can be easily changed and its theoretical background is easily evidenced. Also, it facilitates the understanding of the electromagnetic problem;

## 9. Future works

- ❑ With the aid of this model it is intended to determine the equivalent inductance and resistance of the primary circuit (EMF machine);
  
- ❑ The self inductance of workpiece and mutual inductances changes as workpiece deformation occurs, hence it's necessary to recalculate the currents and electromagnetic forces for each deformation increment of the workpiece. Next goal is to implement such feature in to the present model.

## 9. Acknowledgements

*The authors would like to thank the following persons:*

- Eng. Michael S. Ertle from TDK-EPCOS, for donating the capacitors;*
- Eng. Augusto Nienow from Ensinger Engineering Plastics, for donating of polyoxymethylene block;*
- Eng. Eliseu Silveira Brito for milling the actuator coil and dies;*
- Eng. Marcio Migliavacca from Rexfort for milling the spark-gap parts.*

- [1] *Takatsu N., Kato M., Sato K., and Tobe T.* : High speed forming of metal sheets by electromagnetic force . J.S.M.E. International Journal, vol. 31, no. 1, p. 142-148, 1988.
- [2] *Mamalis, A. G., Manolakos, D. E., Kladas, A. G., Koumoutsos, A. K., Ovchinnikov, S. G.*: Electromagnetic forming of aluminum alloy sheet using a grooved die: numerical modeling. The Physics of Metals and Metallography, Vol. 102, Suppl. 1, p. S90–S93, 2006.
- [3] *Boutana, I., Mekideche, M. R.*: Simulation of aluminum sheet electromagnetic forming with several dies. Systems, Signals and Devices, 2008. IEEE SSD 2008. 5th International Multi-Conference on , p.1-6, July 2008 .
- [4] *Kamal, Manish* : A uniform pressure electromagnetic actuator for forming flat sheets. Dissertation of Graduate Program in Materials Science and Engineering School of the Ohio State University, 2005.
- [5] *Shang, Jianhui* : Electromagnetically assisted sheet metal stamping. School of The Ohio State University, 2006.
- [6] *Meriched, A., Feliachi, M., Mohellebi, H.*: Electromagnetic forming of thin metal Sheets. Magnetics, IEEE Transactions on, vol.36, no.4, p.1808-1811, 2000 .
- [7] *Lange, K.* : Handbook of Metal Forming. Michigan, Society of Manufactures Engineers (SME), 1994.
- [8] *Paese, E.* : Electromagnetic Forming of Thin Metal Sheets: Technical Feasibility. MSc Thesis (in Portuguese), Universidade Federal do Rio Grande do Sul, Brazil, 2010.
- [9] *Xu, W.; Fang, h.; Xu, W.*:Analysis of the Variation Regularity of the Parameters of the Discharge Circuit with the Distance Between Workpiece and Inductor for Electromagnetic Forming Processes. journal of materials processing technology 203 (2008) 216–220.

[http://www.epcos.com/inf/20/30/db/aec\\_09/B43456\\_B43458.pdf](http://www.epcos.com/inf/20/30/db/aec_09/B43456_B43458.pdf) , last access on 02/23/2010.

*Thank you for your attention!*

[epaese@terra.com.br](mailto:epaese@terra.com.br)  
[geier.martin@gmail.com](mailto:geier.martin@gmail.com)