



Constitutive relation development through the FIRE test

**J. R. Johnson¹, G. A. Taber¹, and G. S. Daehn¹
H. Chu², J. Lacy², Gregg Fenton³**

¹Ohio State University 477 Watts Hall, 2041 College Rd, Columbus, Ohio, USA

²Idaho National Labs, ³Applied Research Associates

4th International Conference on High Speed
Metal Forming (ICHSF)

March 10th, 2010

Overview

- Fully Instrumented Ring Expansion (FIRE)
- Motivation & Background
- Equipment Development
 - Velocimetry
 - Actuators
- Experimental Results
- Future Work
- Conclusions

Motivation

- High rate deformation is difficult to characterize, yet constitutive properties in this regime are valuable
- Traditional high rate tensile testing is limited by the Von Karman velocity:

$$v_{VK} = \sqrt{\frac{\partial \sigma / \partial \epsilon}{\rho}}$$

- SHPB limited to $\dot{\epsilon} = \sim 1000 \text{ s}^{-1}$ in tension
- Compression tests are possible at high rate, but can't account for T-C asymmetry
 - Additional correction factors needed as well

Motivation

- Ring expansion testing has been shown to be unaffected by the Von Karman velocity, due to geometric factor
 - 2D as opposed to 1D loading
 - Strain produced by a uniform velocity gradient
- Simple uniaxial tension – provided by symmetry
 - Caveat: thin rings, where thickness $< \sim 10 \cdot (\text{radius})$
 - More complicated analytical analyses and/or FEA can potentially deal with 2D effects in thick rings (future) ...
- Potential application in many materials systems
 - Not just good conductors

Background

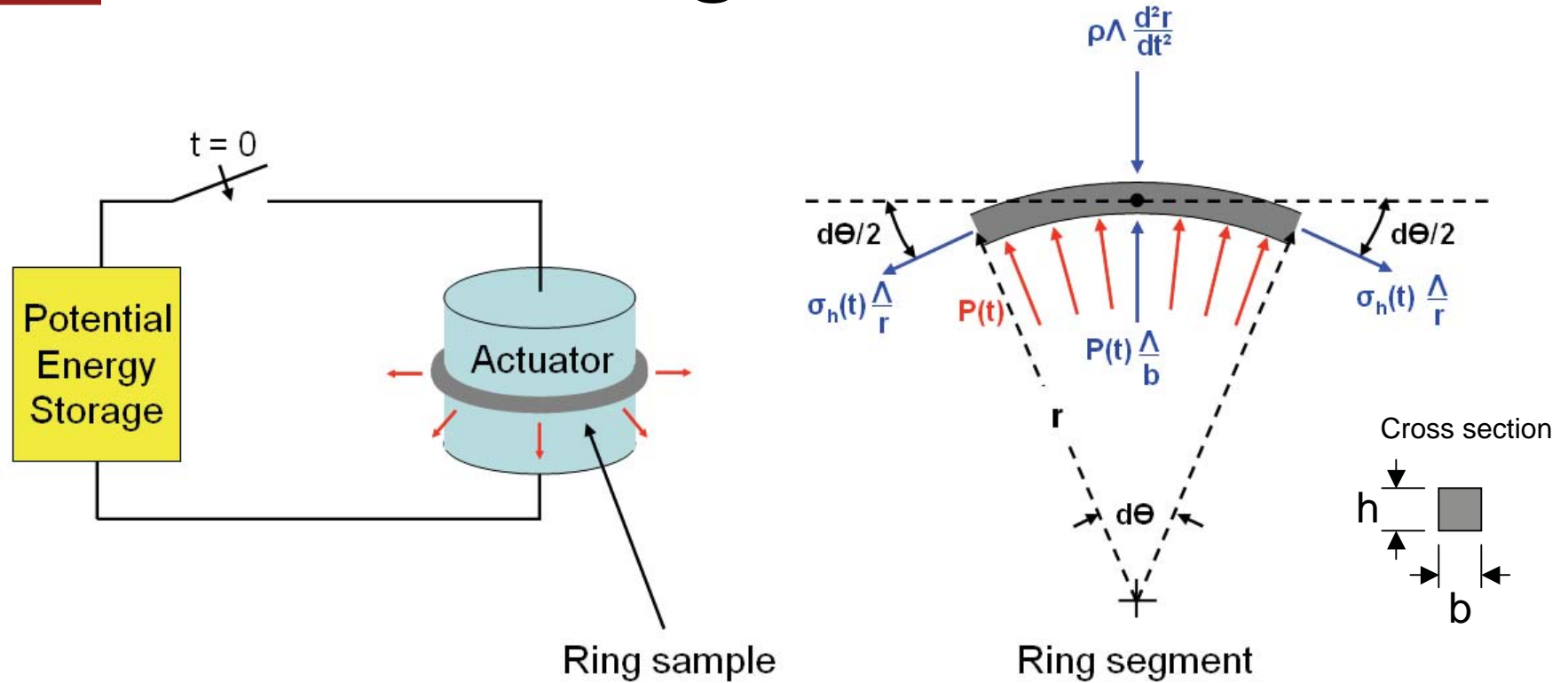

$$\Lambda = bhrd\theta$$



$$\rho\Lambda \frac{d^2r}{dt^2} = P(t) \frac{\Lambda}{b} - \sigma_h(t) \frac{\Lambda}{r} \quad \rightarrow \quad \text{For } P(t) \approx 0 \quad \rightarrow \quad \sigma_h(t) = -r\rho \frac{d^2r}{dt^2}$$

Background

- Stress state can be varied from plane stress to plane strain with choice of sample cross section aspect ratio
 - Due to inertial constraint in the axial direction

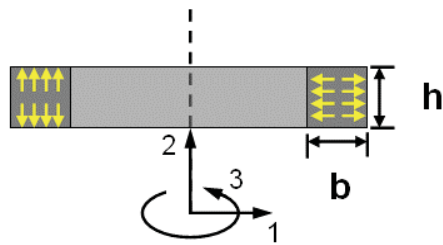

Plane stress: $\epsilon_1 = \epsilon_2 = -\epsilon_3/2$

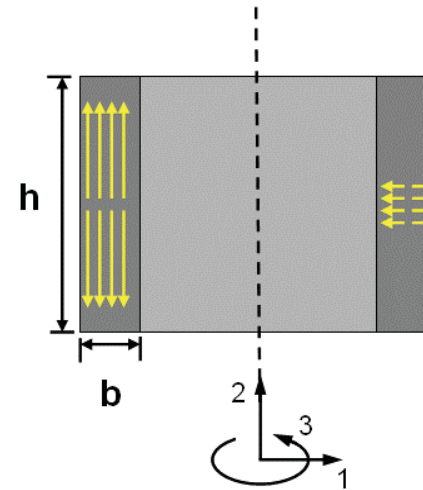

Plane strain: $\epsilon_2 = 0, \epsilon_1 = -\epsilon_3$

Background

- Photon Doppler Velocimetry (PDV) has provided accurate measurements that are simple to acquire and analyze

Beat frequency from recombined reference and Doppler shifted light:

$$f_{beat}(t) = 2 \left[\frac{v(t)}{c} \right] f_o$$

f = frequency (Hz)

v = velocity (m/s)

t = time (s)

$c = 2.998 \cdot 10^8$ (m/s)

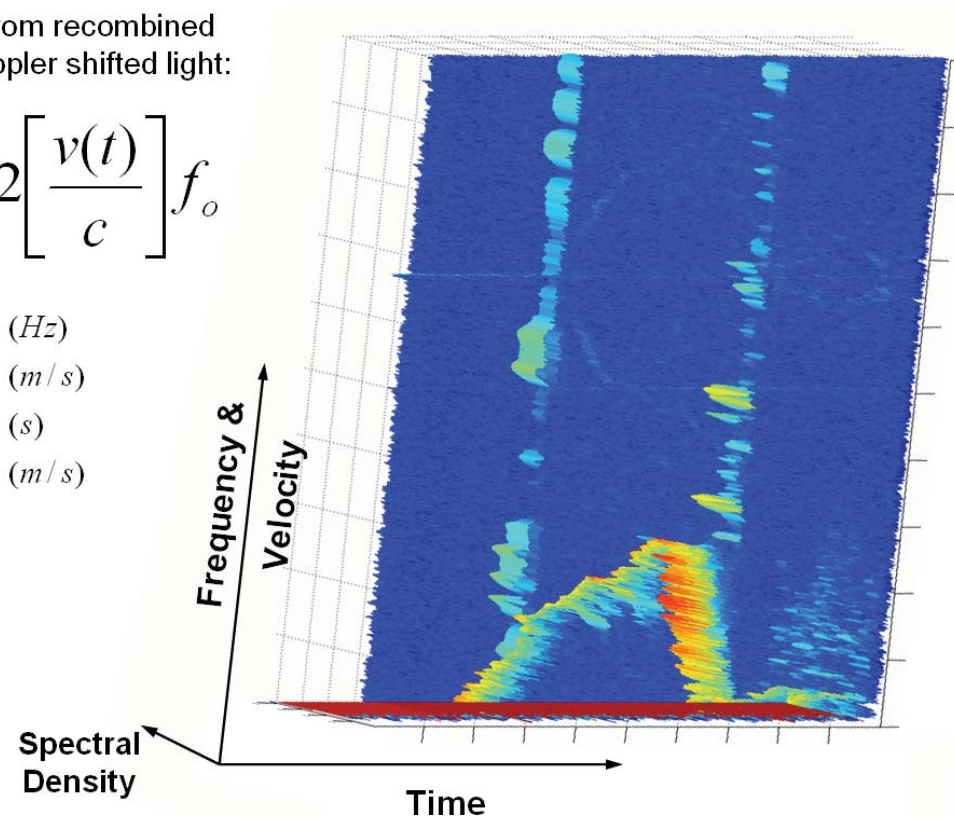

MatLab command: "spectrogram" - `spectrogram(pdvdat,t,(t/2),f,fs);`

Velocimetry

- OSU's PDV system consists of:
 - 1 watt Er fiber laser: $\lambda = 1550$ nm
 - Stable, tunable, 3 kHz line width
 - 1 GHz digital storage oscilloscope
 - 1.5 GHz photodetectors
 - Various optical components and probes
- Measurement specifications:
 - 0 to 1 km/sec
 - 1 ns temporal resolution
 - 1 μm spatial resolution



Velocimetry

- Recently discussed Photon Doppler Accelerometer (PDA)
 - Measuring acceleration directly avoids issues that arise when differentiating high speed signals
- Proof of concept has been demonstrated
 - Simple additions to PDV system are all that is needed
 - Laser sources are stable enough to avoid phase noise over the periods of interest for t_{delay}

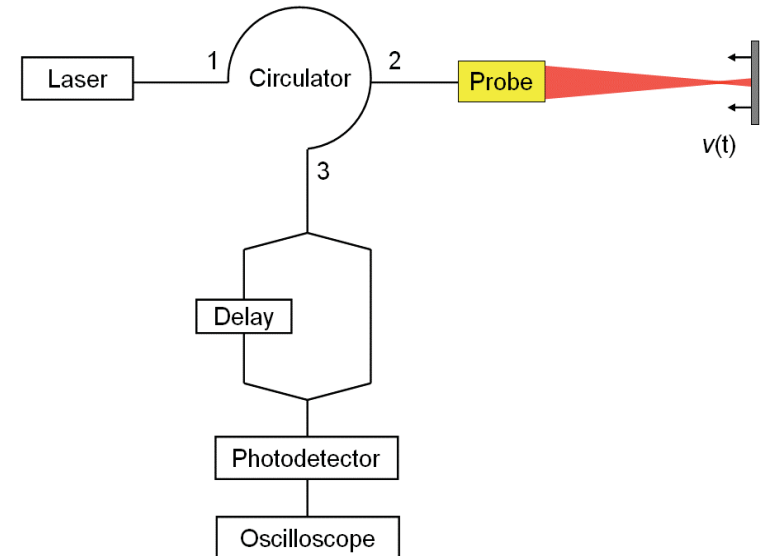

Probe must be a non-back reflecting type for PDA (specify as -60 dB return loss)

Actuators

- Electro-Magnetic (EM)
 - Improvements in construction technique have produced highly accurate, robust actuators
 - Repeatable use energy limit > 10 kJ
 - CNC machined coils from billet C18150
 - Spectra fiber filament winding adds strength

Machined coil



Brazing and coating

Example: Tube Compression Actuator



Filament winding

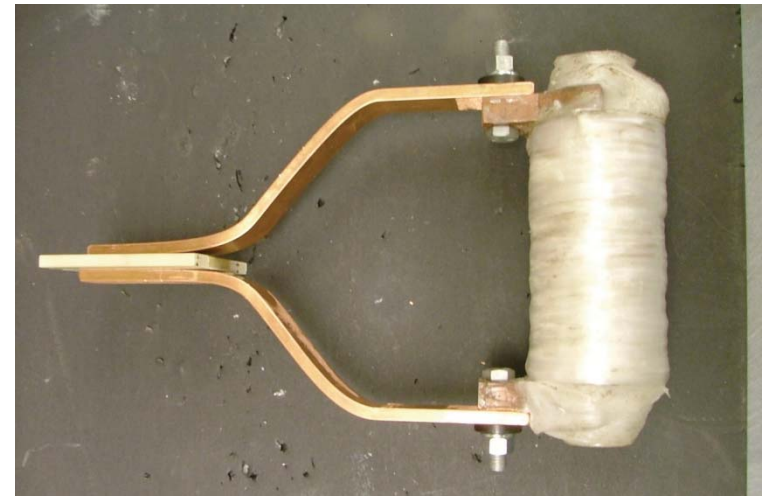

Actuators

- Exploding Wire (EW)
 - Disposable – no energy limitation
 - Have had good luck with polyurethane as pressure transfer medium
 - 0.060" diameter Al welding wire works well
 - Optional radial steel constraint rings provide a pressure history that is much closer to an ideal delta function

EW vs. EM actuator

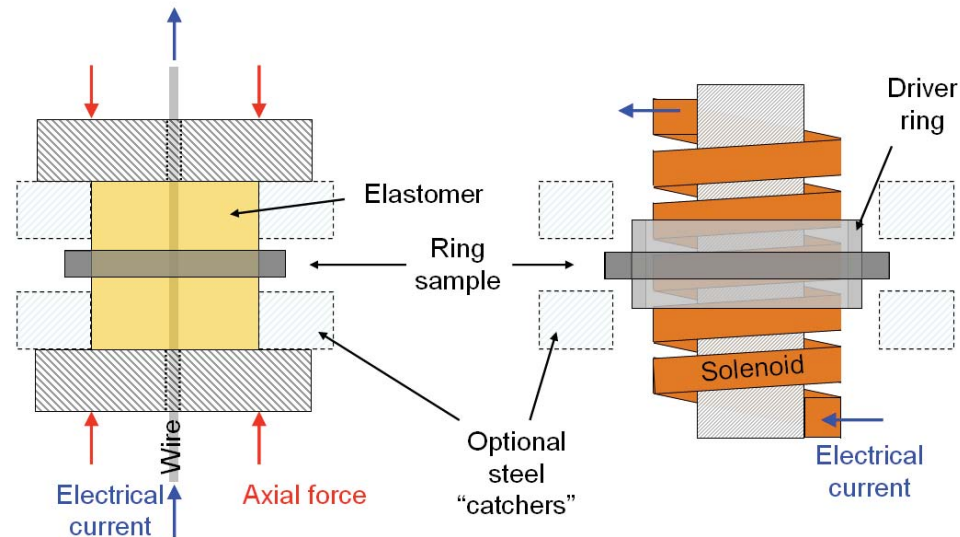

The FIRE System

- Fully Instrumented Ring Expansion (FIRE)
 - Combines up to 6 channels of velocimetry and ability to precisely measure current & voltage from power supply
 - Interchangeable EW and EM actuators
 - Machine tool accuracy

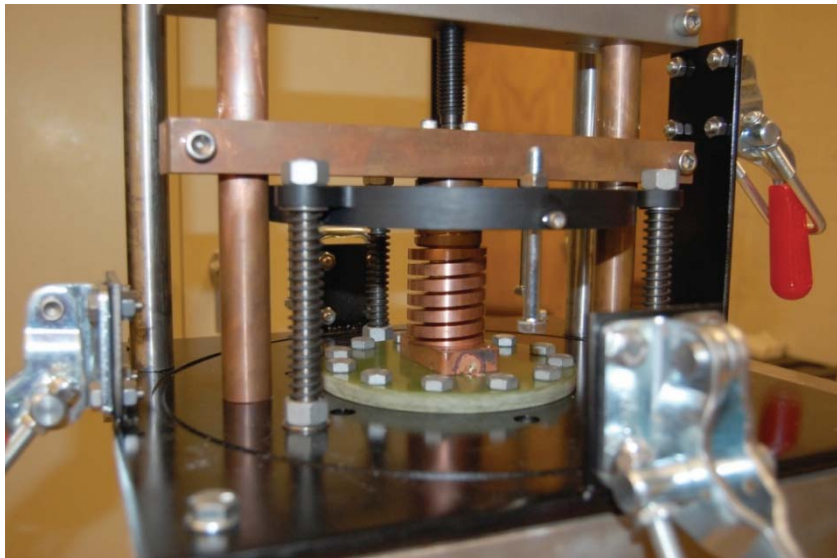

The FIRE System

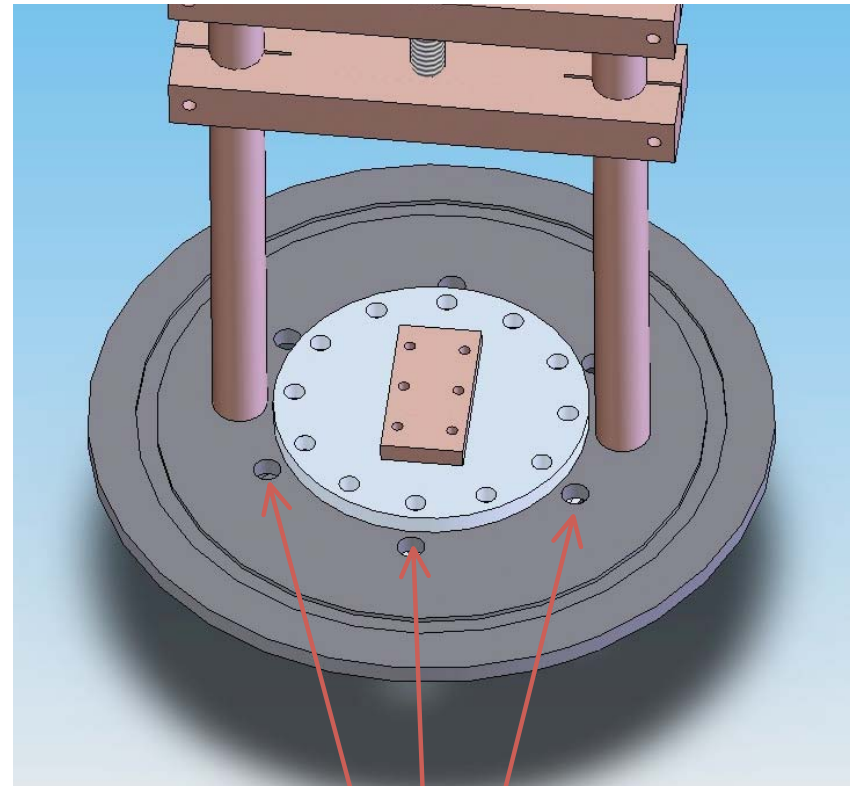
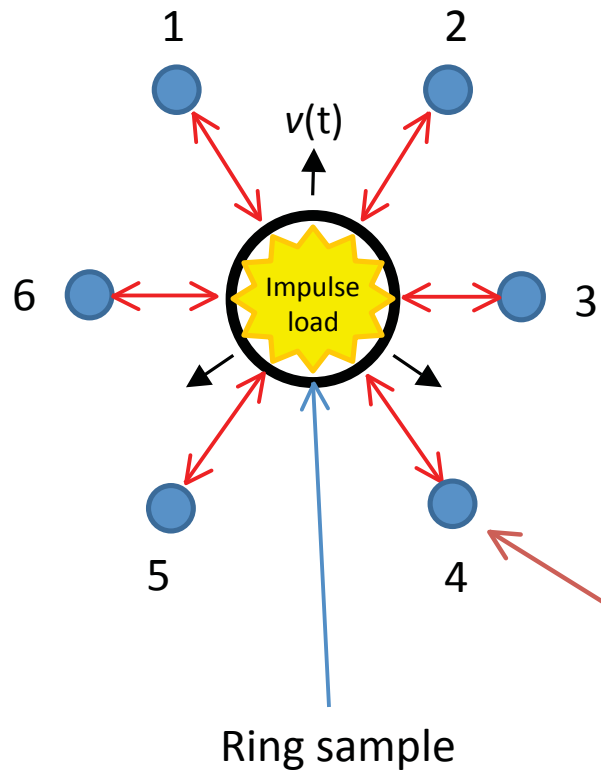

PDV ports

The FIRE System

Symmetric current path:

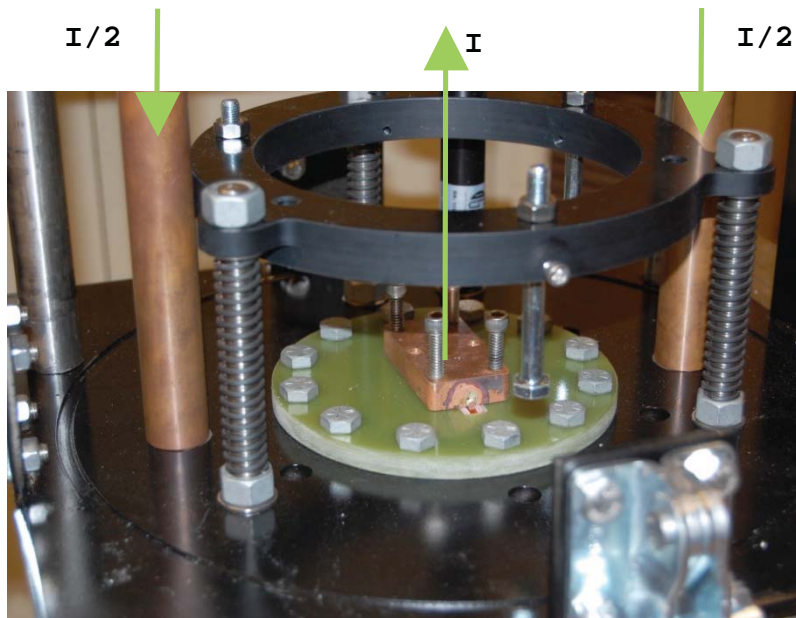

- PDV support ring is located in a plane via 3 threaded posts
- Can independently or simultaneously adjust all 6 PDV channels for axial height
 - Useful on long tube samples

Experimental Results

- Indirect expansion of polycarbonate rings
 - 2" inside diameter, 0.12" wall thickness extruded polycarbonate tube
 - 0.12" sample height
- Summary of 6 shots
- Compare bare driver to composite driver/sample

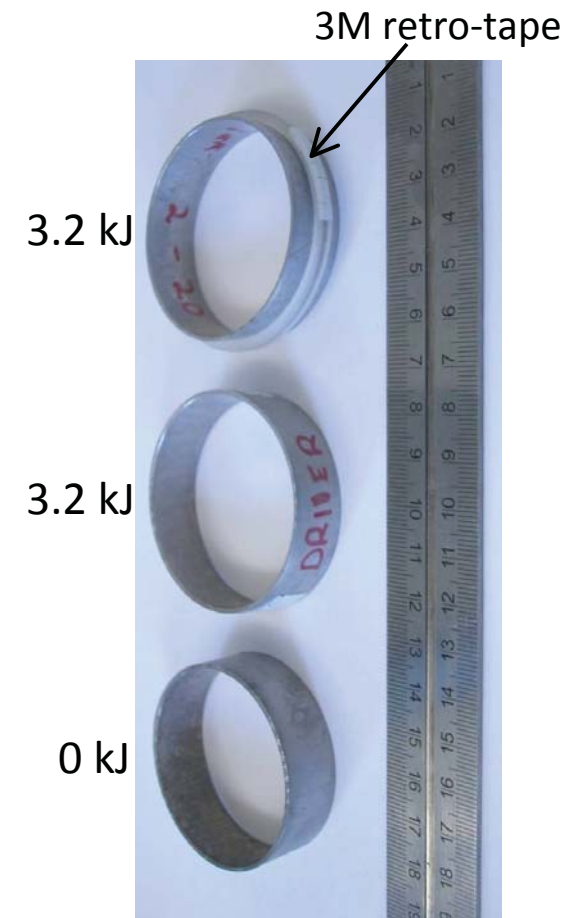
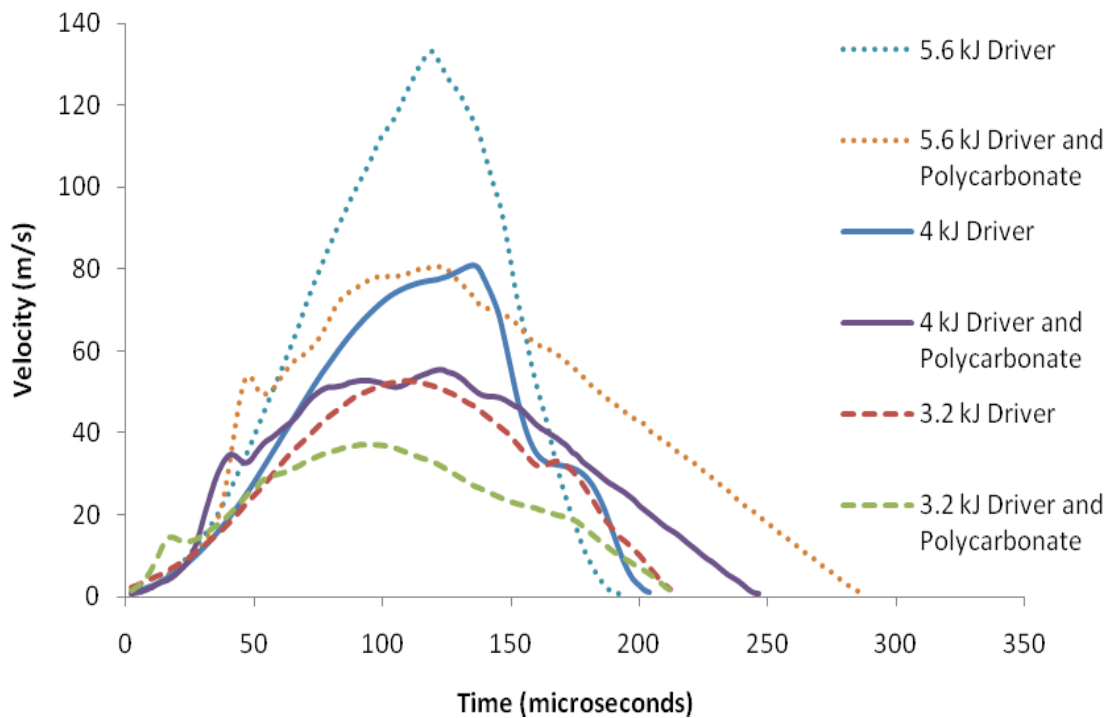

Experimental Results

- Indirect EM expansion of polycarbonate rings
- Data is from 10 cm focal length, -15 dB PDV probes

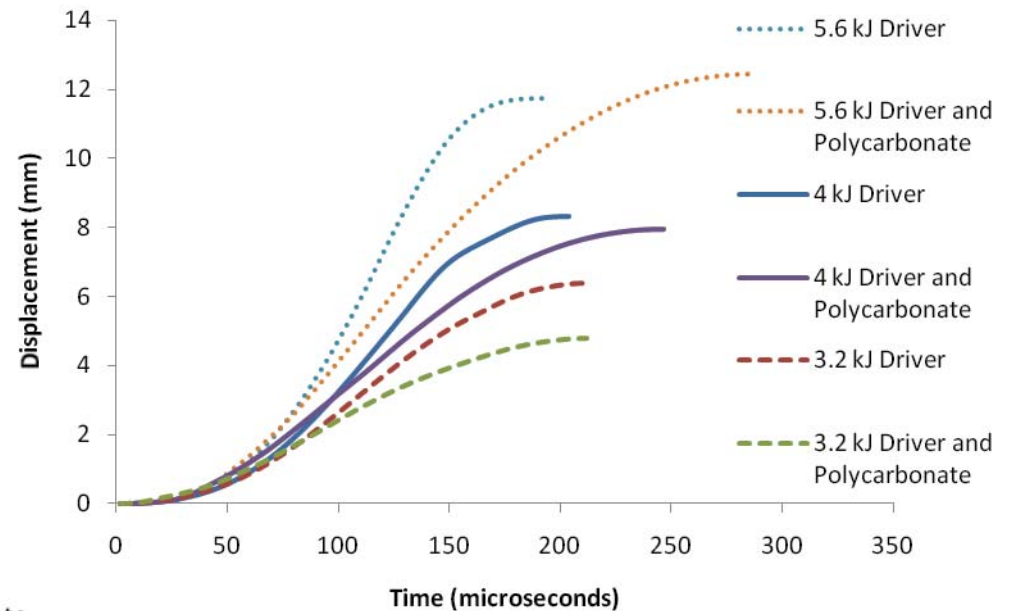
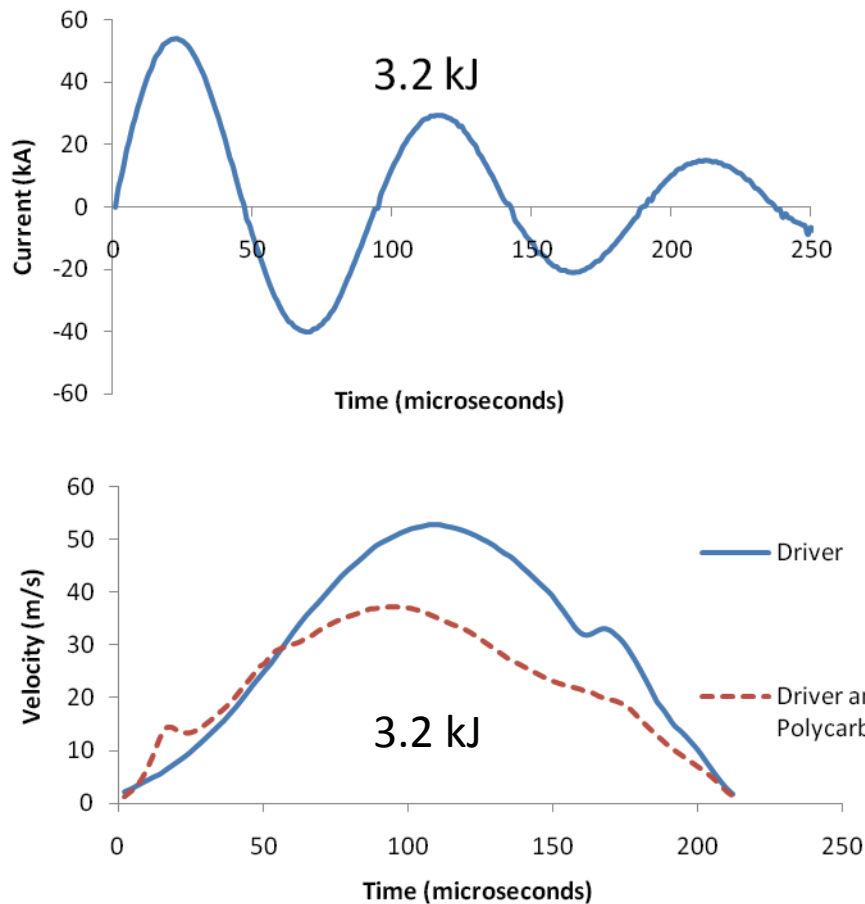

Experimental Results

- EW expansion of AISI 4130
 - 1.027" inside diameter, 0.049" wall thickness seamless DOM tube
 - 0.375" sample height
 - 1" long, 1" outside diameter extruded urethane actuator body
 - Durometer rating: 80 Shore A
 - 6.4 kJ shot energy

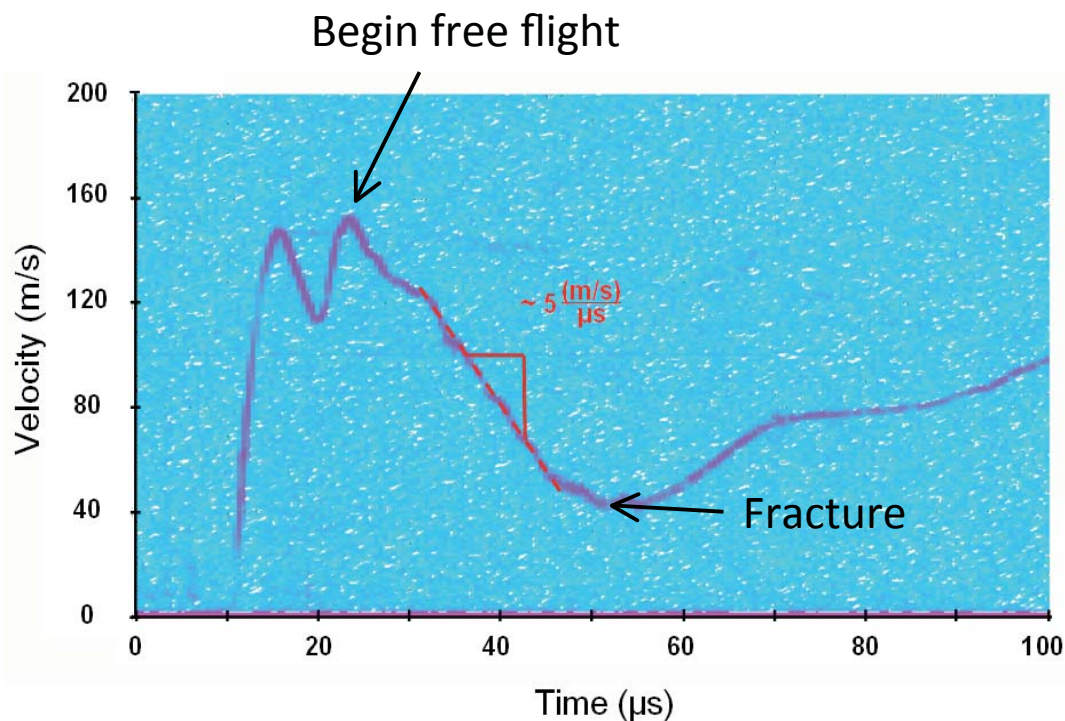

30 cm focal length, -15 dB probes were used in this experiment

Peak strain rate $\sim 12000 \text{ s}^{-1}$

Experimental Results

- EW expansion of AISI 4130 HSLA steel
 - Track displacement and strain rate of region shown above
 - Use freely expanding ring analysis
 - Fit constitutive model of choice to data

$$\sigma_h(t) = -r\rho \frac{d^2 r}{dt^2}$$

$\circlearrowleft \frac{d^2 r}{dt^2}$
 \swarrow
 $-5 \times 10^6 \text{ m/s}^2$

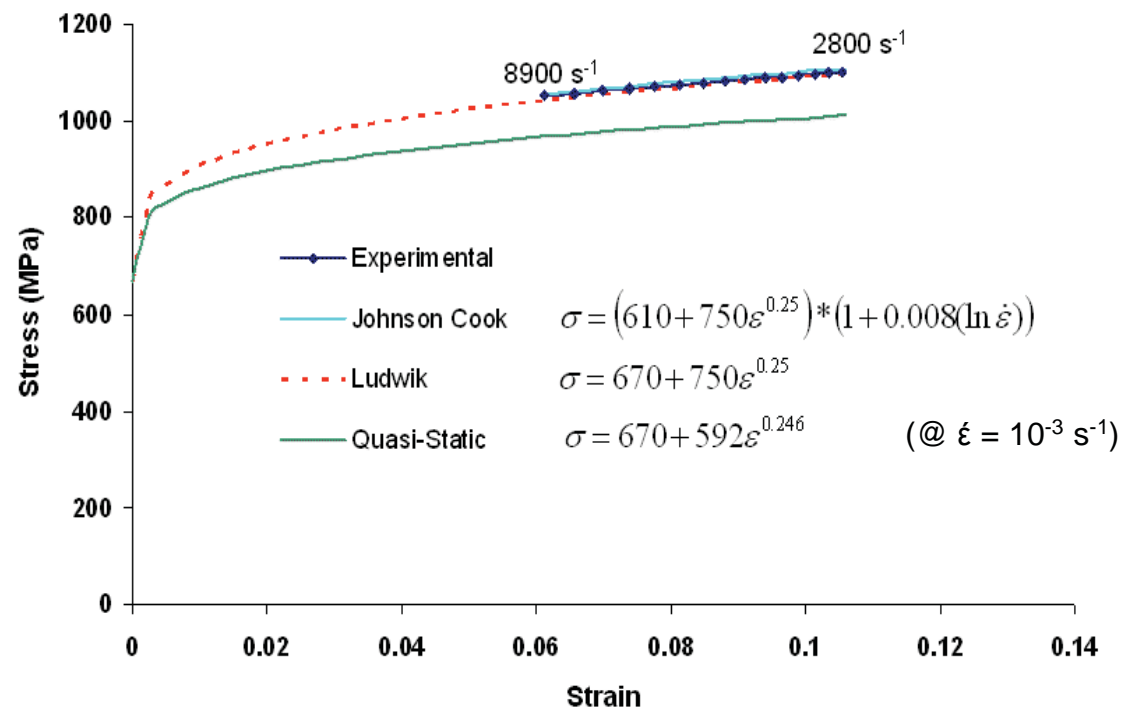

Future Work

- Elevated temperature testing is a priority
 - Can use ceramic fiber or graphite tape to thermally isolate samples from actuator
 - Initially heating will be accomplished by radiant and/or convective transfer
 - Later revision will likely incorporate induction heating
 - Thermocouple probes and/or infrared thermal detector will be added
- Geometries other than the simple ring and expansion actuator
 - Notched rings for fracture toughness
 - Compressive variant – already demonstrated, needs adaptation to FIRE system
 - Collapse of tubes filled with a compressible media
 - Shear variant – addition of tool steel ring with shearing edge

Conclusions

- Ring expansion offers rapid assessment of tensile properties in ductile materials
- Constitutive parameters can be extracted
 - This is easiest for the freely expanding ring
- High speed velocimetry is an indispensable tool in the FIRE system arsenal
 - PDV is becoming well established
 - PDA is promising

Comments?

