

Commercialization of Fuel Cell Bipolar Plate Manufacturing by Electromagnetic Forming

J. Shang¹, L. Wilkerson¹, S. Hatkevich¹
G. Daehn², J. Bradley³

¹ American Trim LLC, Lima, Ohio USA

² The Ohio State University, Columbus, Ohio USA

³ General Motors R&D Center, Warren, MI USA

* This project was funded by the Ohio Third Frontier Fuel Cell Program. And the authors thank LSTC for providing Ls-dyna electromagnetism module.

Outline

- Functional requirements of PEM fuel cell plates
- Electromagnetic forming to manufacture fuel cell plate
- Preliminary results
- Velocity measurement and simulation
- Coil durability and die wear
- Summary

PEM Fuel Cell Bipolar Plates

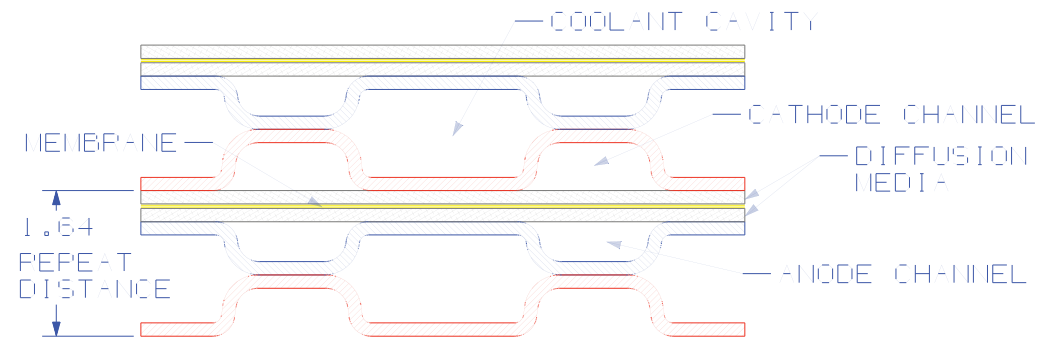
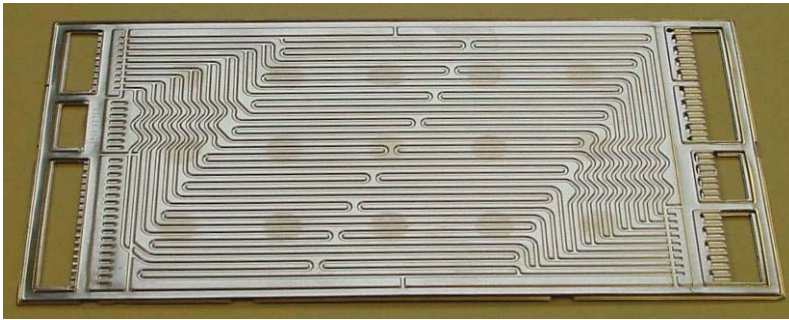

- Functional requirements:
 - Strong, light, thin
 - Corrosion resistant
 - Joinable
 - Formable into complex shapes

Candidate Materials

- Plate material selection
 - Meet functional requirements
 - Material and manufacturing costs have historically been the largest contributor to total plate cost.
- Stainless steels as candidate materials
 - Corrosion resistance, formability, high strength, low cost, joinable,
 - Austenitic SS (304, 316, 201, ...)
 - Ferritic SS (409, 430, 439, ...)

Production needs

Volume requirements are potentially very large:

- 2 plates (anode + cathode) per bipolar plate assembly
- ~ 500 bipolar plate assemblies per stack (per vehicle)
- Potential market 1,000,000 vehicles per year

A high volume and low cost manufacturing process is needed.

Possible Forming Methods

- Machining
- Hydro-forming
- Conventional stamping
- High velocity forming
 - Electromagnetic forming

Basic Layout of Electromagnetic Forming

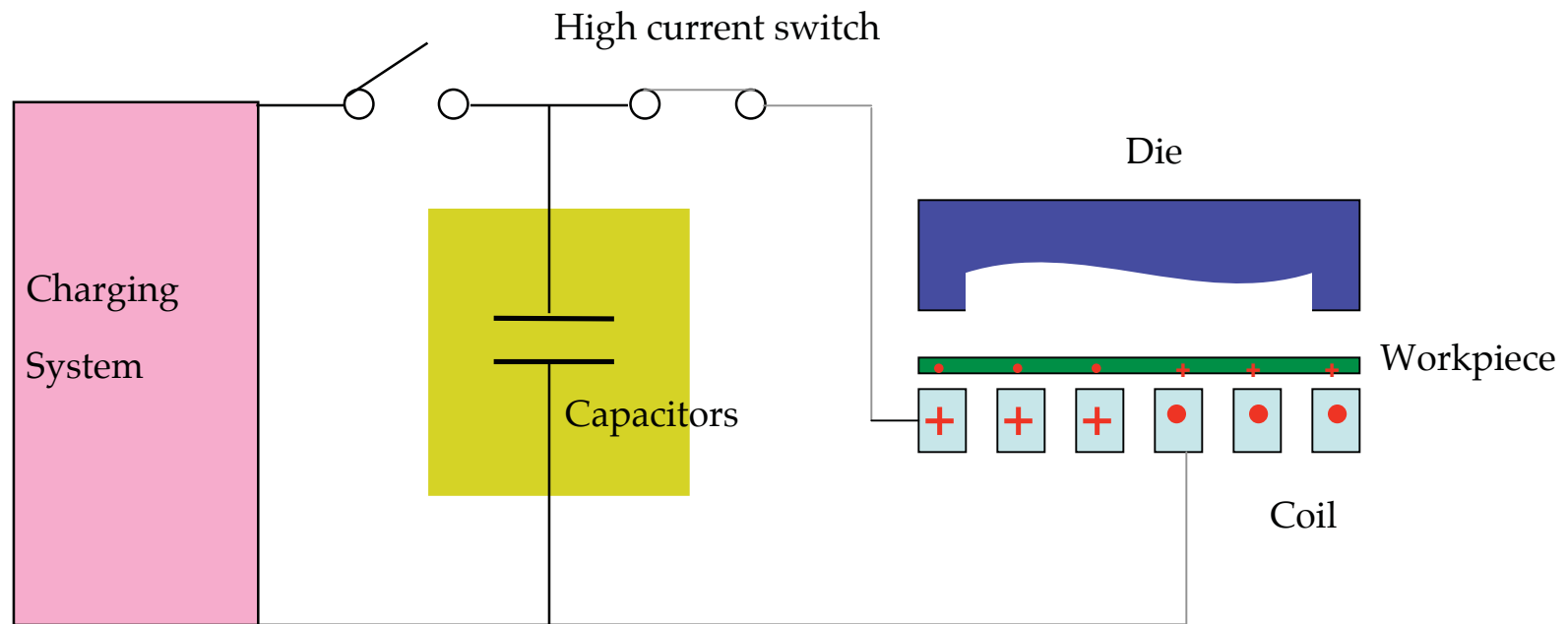

Press Forming vs. Electromagnetic Forming



	Traditional Stamping	Electromagnetic Forming
Tool	Must have die and Punch	Single-side die
Alignment	Carefully aligned for punch and die	Simple alignment
Formability	Good formability is required	Better formability because of high velocity and strain rate
Late Stage Changes	Difficult due to tolerance requirements for die and punch	Easy because of single-side die
Pressure	Press tonnage, heavy tooling	Large pressure from high velocity impact. Lighter tooling are possible

Apply Electromagnetic Forming to manufacture PEM fuel cell plate

Challenges:

- (1) Low conductivity of stainless steel ---- Driver plate needed;
- (2) Uniform pressure needed;

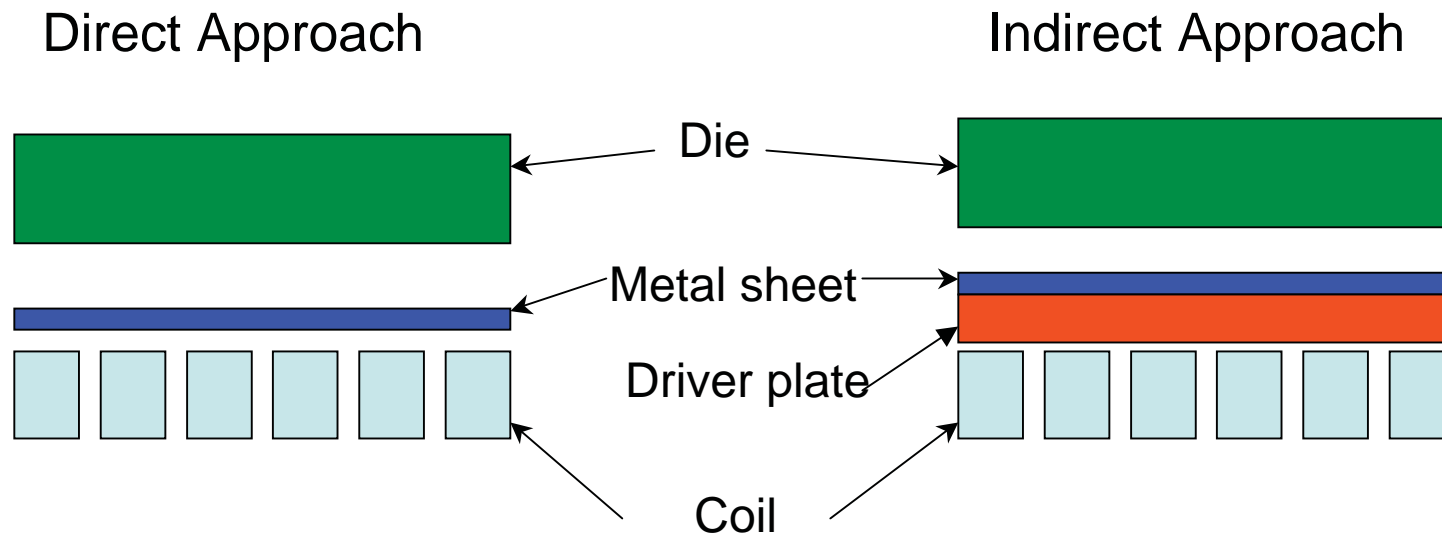

Compliant Layer Electromagnetic Forming

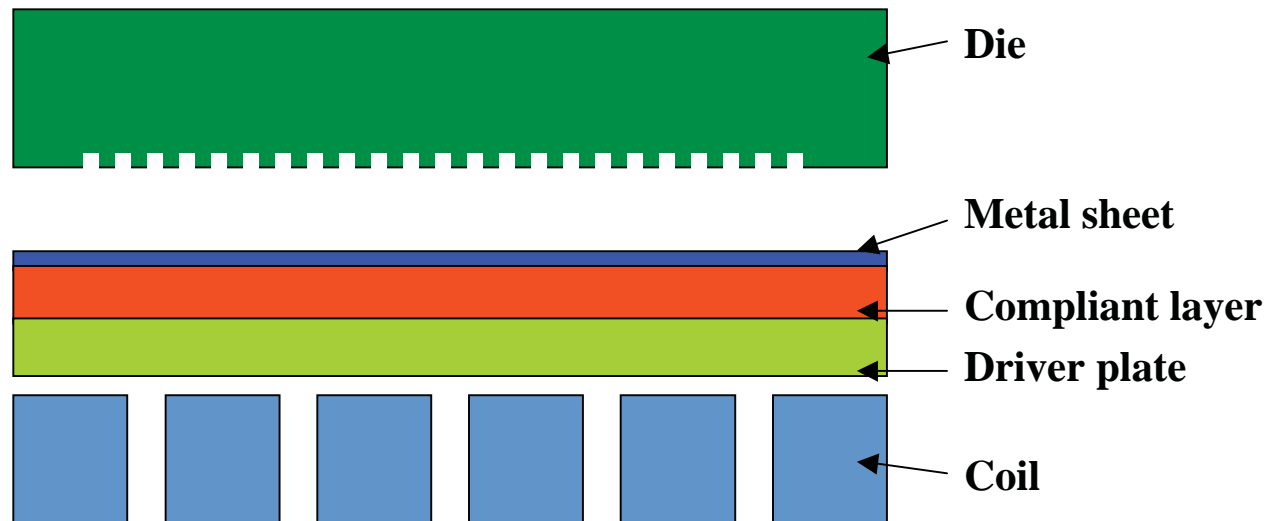

- Advantages: (1) Driver plate is re-usable, which reduces cost;
(2) Uniform pressure;
(3) Easy automation;

Technologies of high velocity press

<i>Technology</i>	<i>Speed</i>	<i>Ram Mass</i>	<i>Drive means</i>
Drop hammer press	2-5 m/s	Massive	Gravity
Airam press	~ 10 m/s	Modest	Air driven
Lourdes-Neutronic press (Winset)	~10 m/s	Modest	EM solenoid
Cell impact press (Morphic)	~50 m/s	Modest - light	Hydraulic actuation
LMC press	~ 50 m/s	Modest - light	Spring driven
EM Compliant Layer (AmTrim)	>50 m/s	Light	EM actuator
Direct EM actuation	>150 m/s	None	EM actuator

Concept of Fuel Cell Plate Manufacturing by Electromagnetic Forming

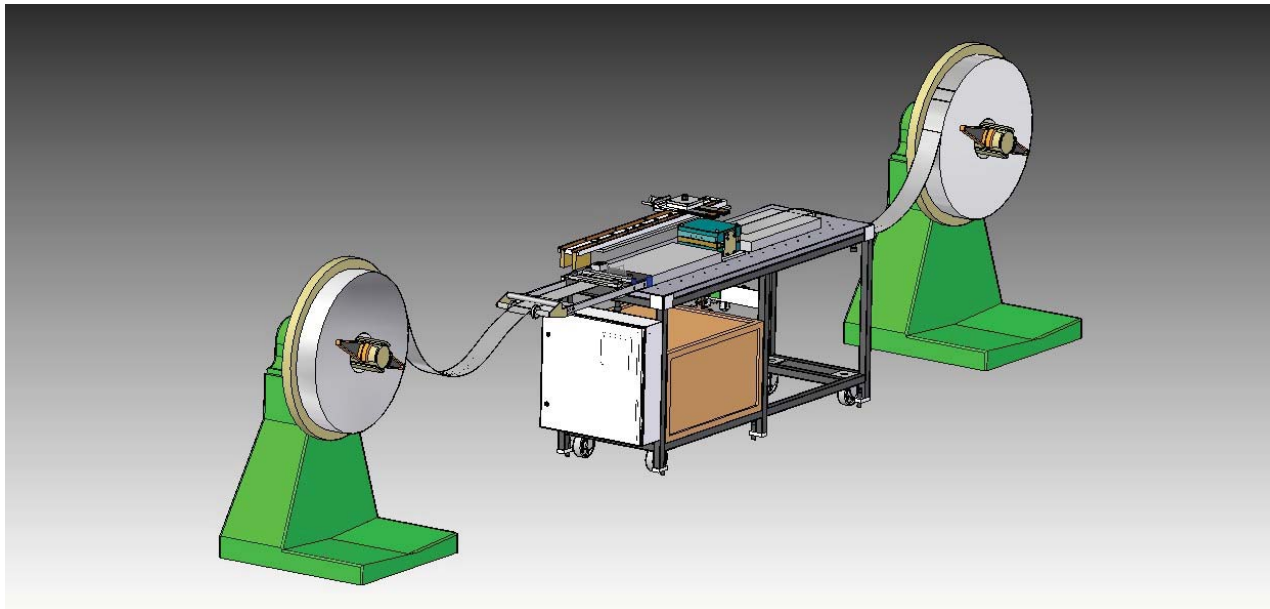

- Automation is easily applied to the process.
- One sided die eliminates alignment and complexity issues.
- Quick tool change is easy to implement.

Alpha Machine in AmTrim with Preliminary Results



Setup and Sub-Sized Bipolar Plates Formed by Alpha Machine



Setup

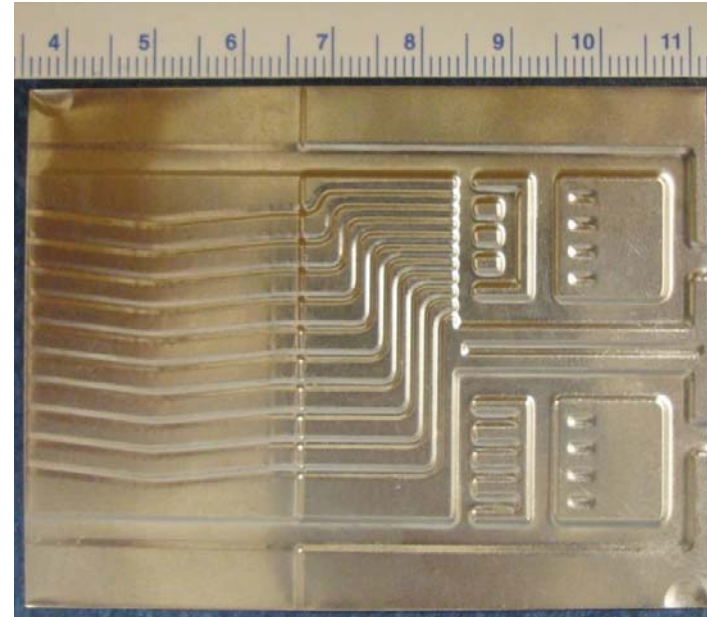

A typical formed plate
(0.1mm Stainless Steel 201)

Preliminary Results

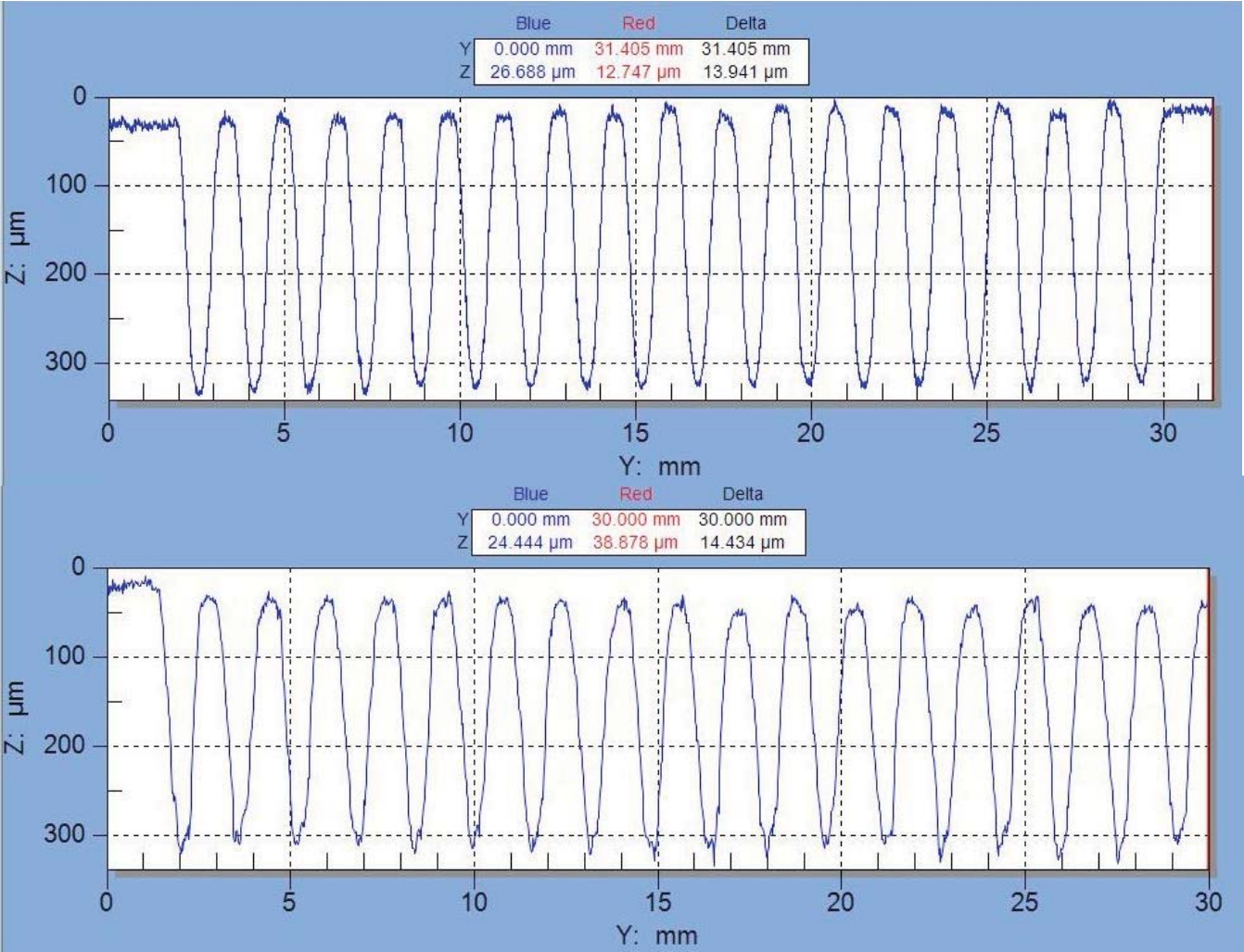

Die scanning
(311μm channel depth)

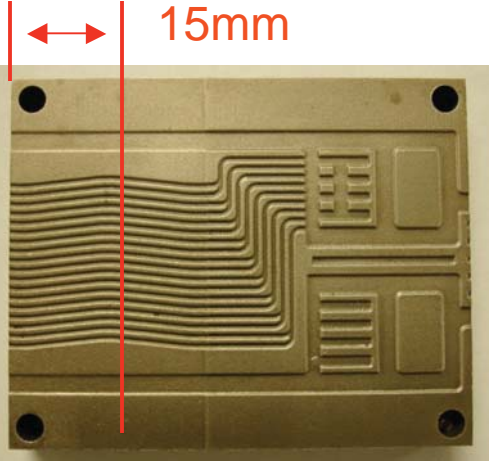

Formed part scanning (0.1mm 439SS, 9 kJ, 260μm channel depth)

Photo of One Channel

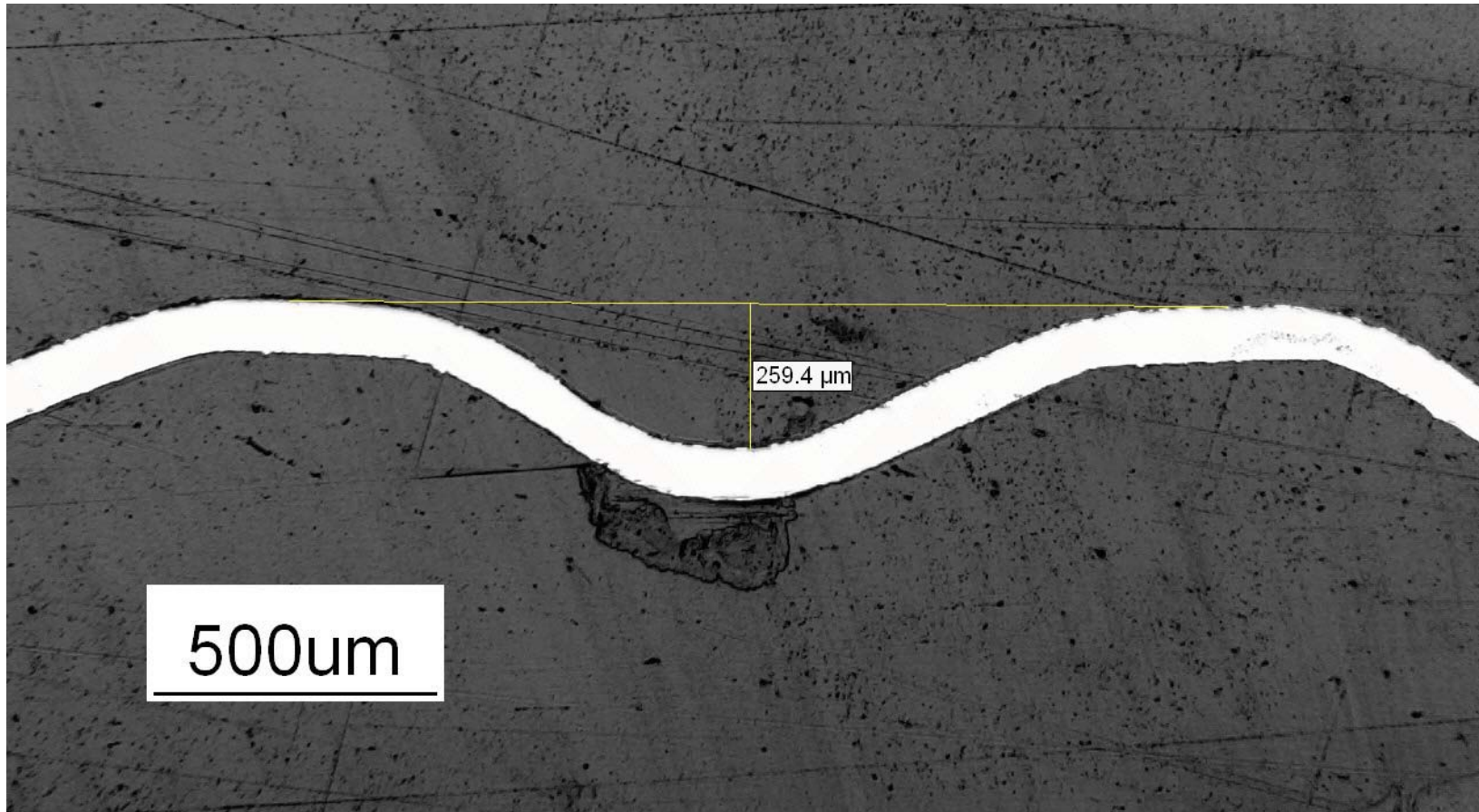

Formed part (0.1mm 439SS, 9 kJ, 260µm channel depth)

Velocity Measurement by Photon Doppler Velocimeter

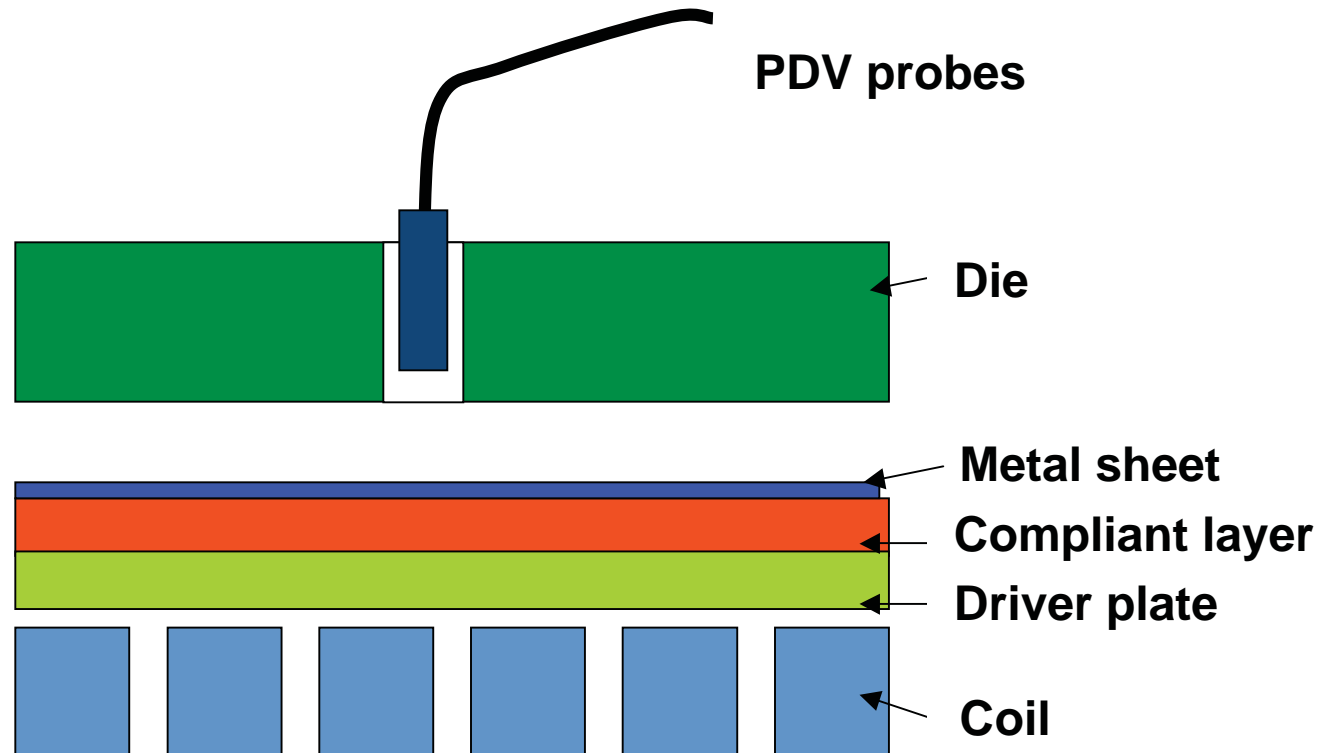

Result of OSU PDV Measurements

Measured
Velocity of Driver
Plate

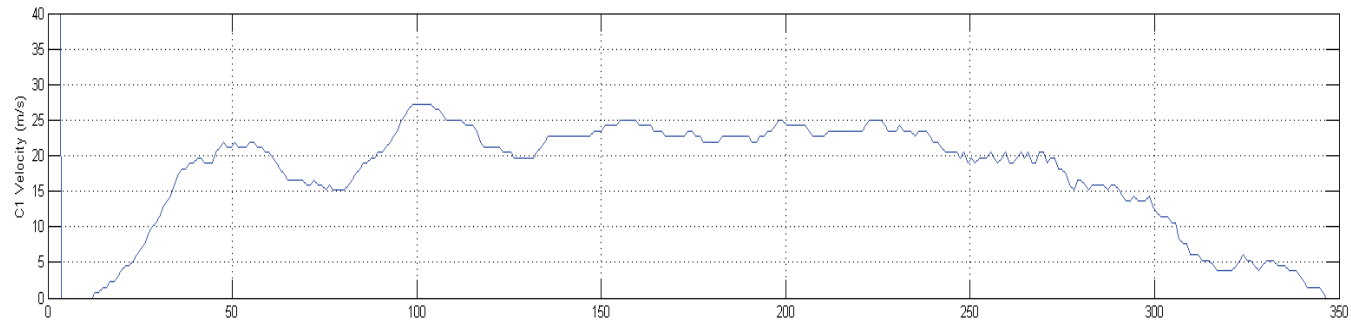

Measured
Current Trace

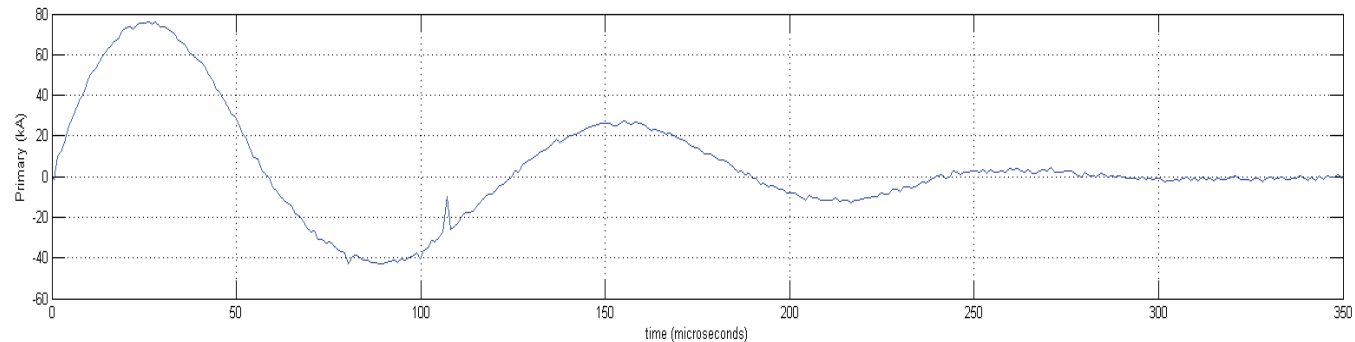

The energy input was 2.4 kJ and only driver plate was applied.

**Data were provided by OSU.*

Result of OSU PDV Measurements

Measured Velocity of Driver Plate plus Compliant Layer

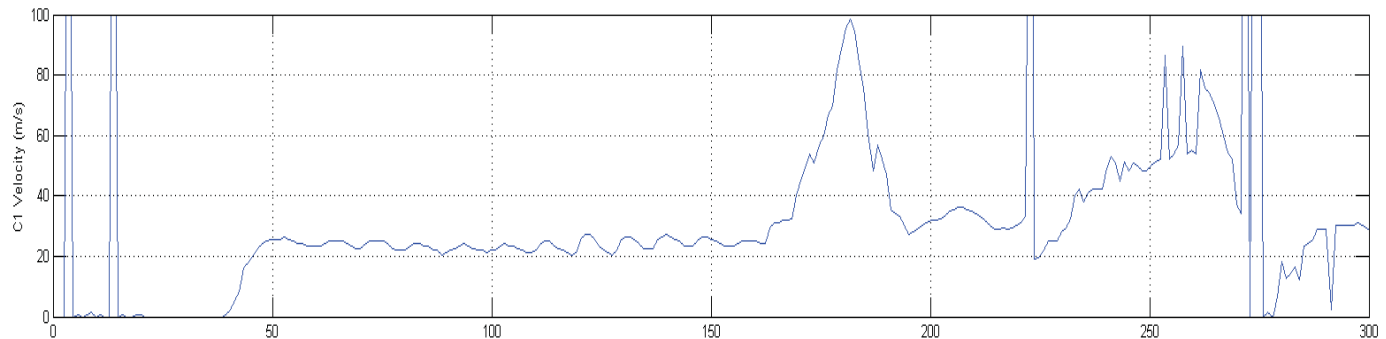

Measured Velocity of Driver Plate

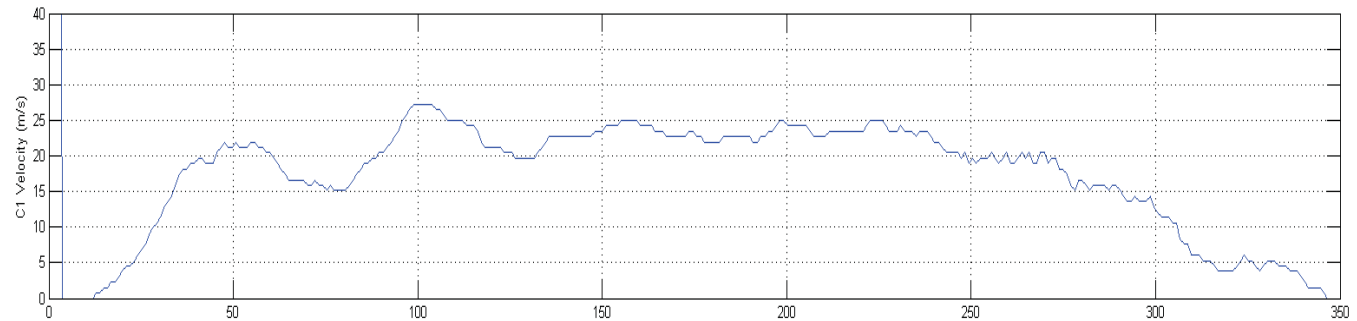

The energy input was 2.4 kJ.

*Data were provided by OSU.

Comparison between Measurement and Simulation

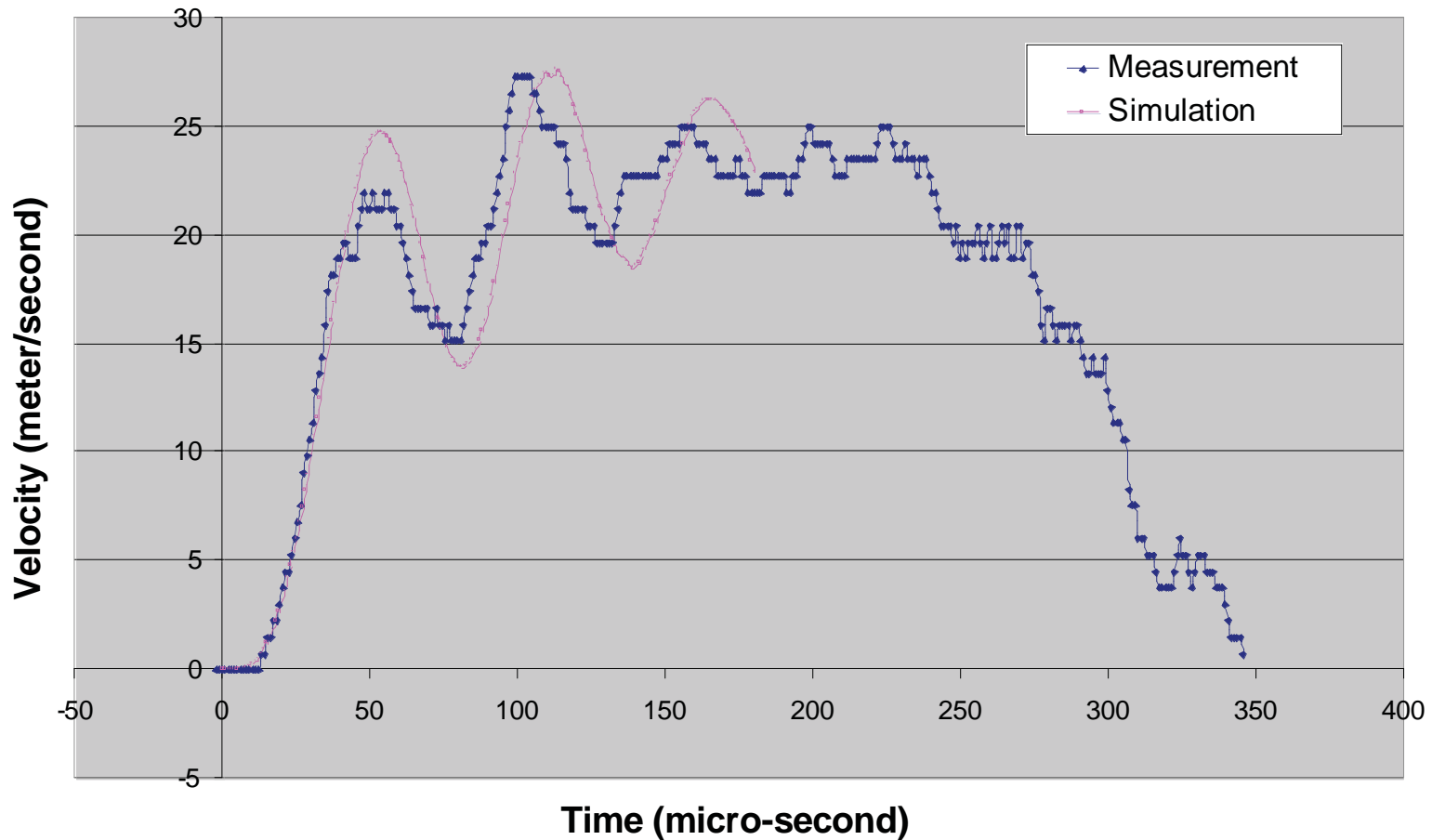

The energy input was 2.4 kJ and only driver plate was applied.

Comparison between Measurement and Simulation

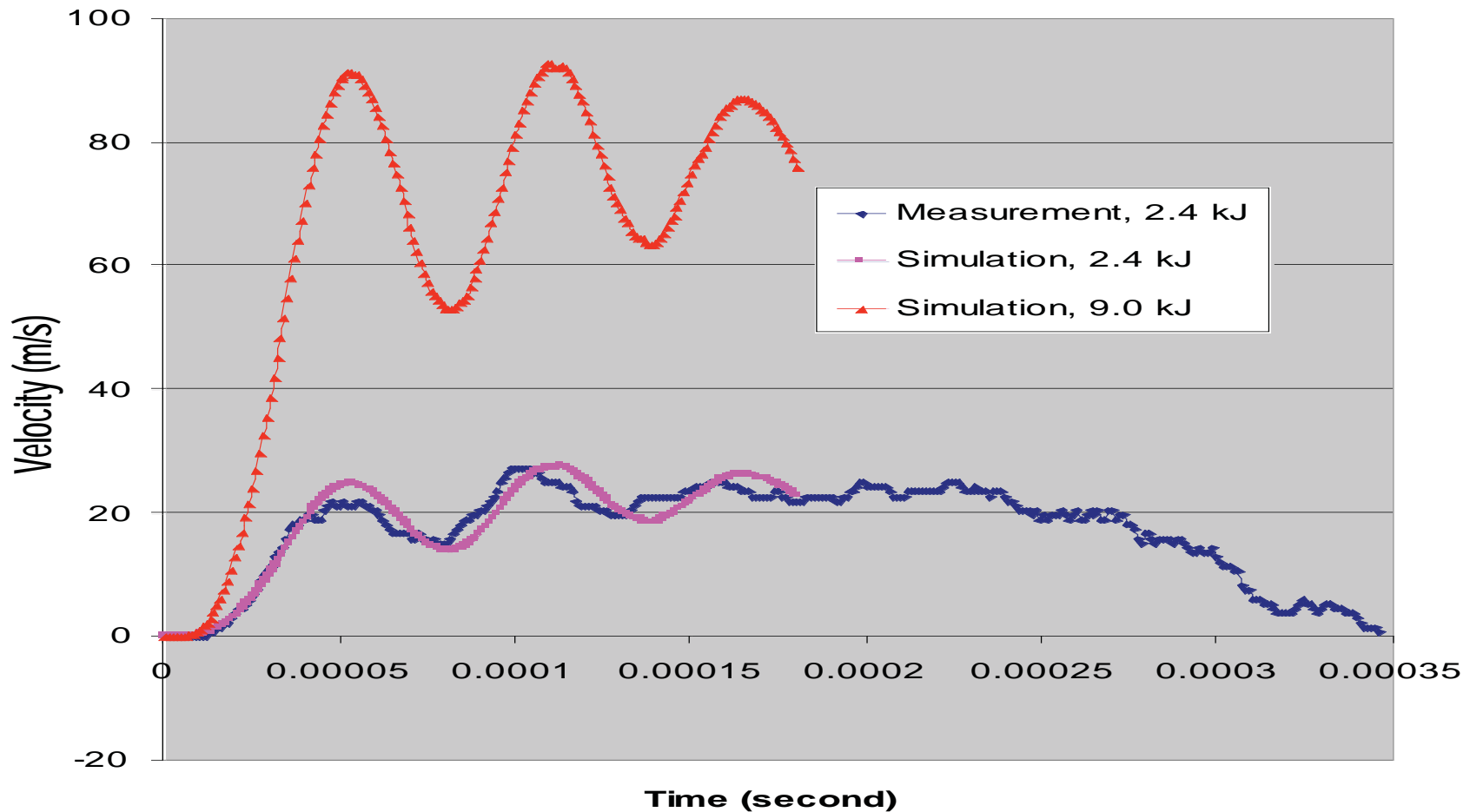

Only driver plate was applied.

Coil Durability

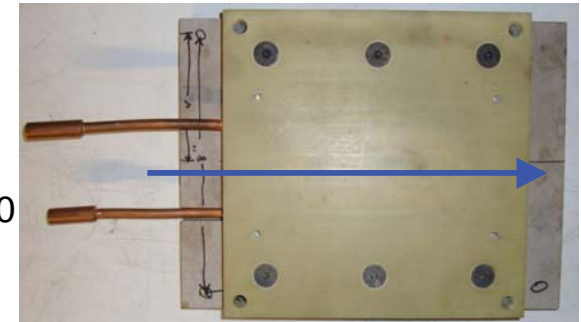
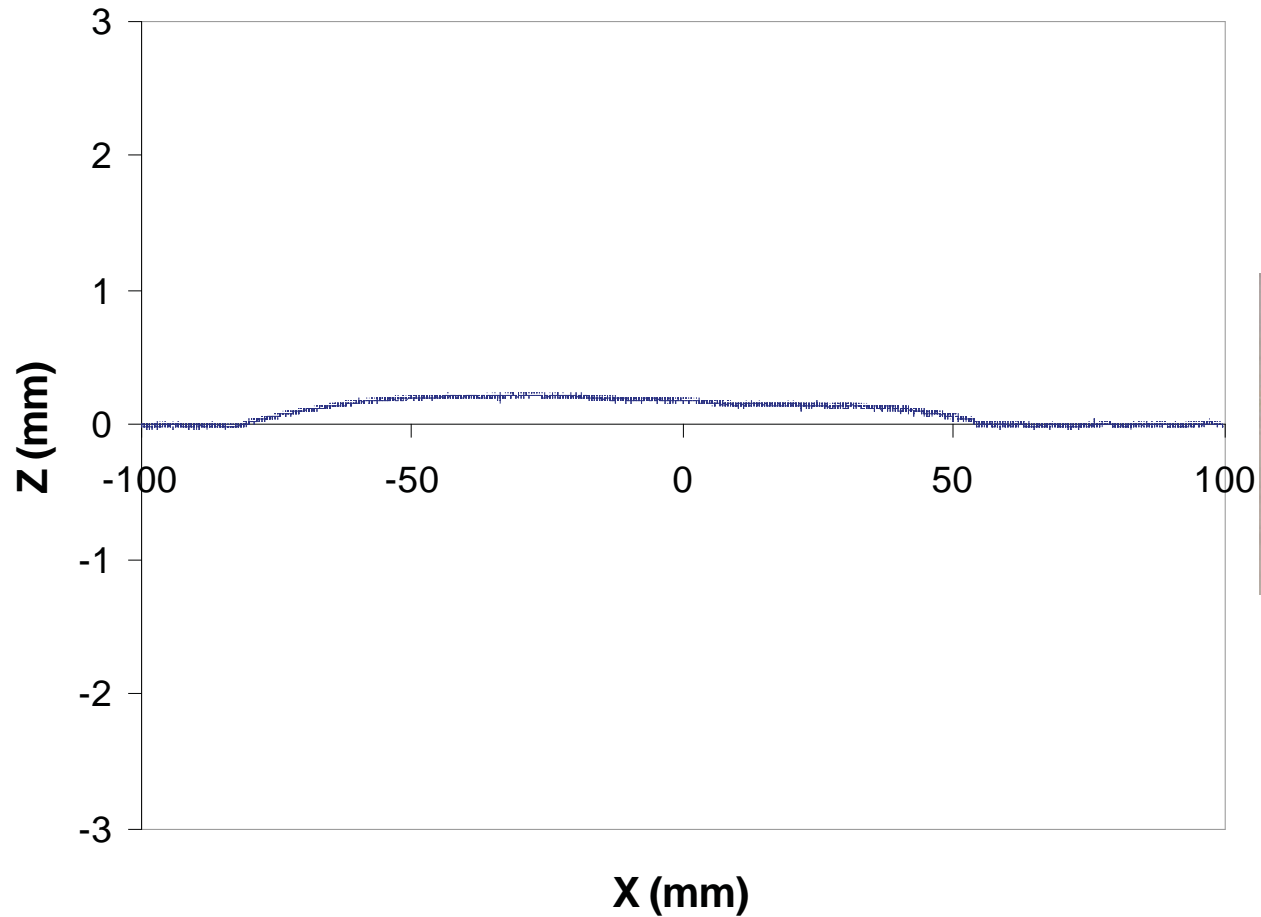

Scanning along the middle line of the coil (after around 500+ hits, initially flat)

Die Wear

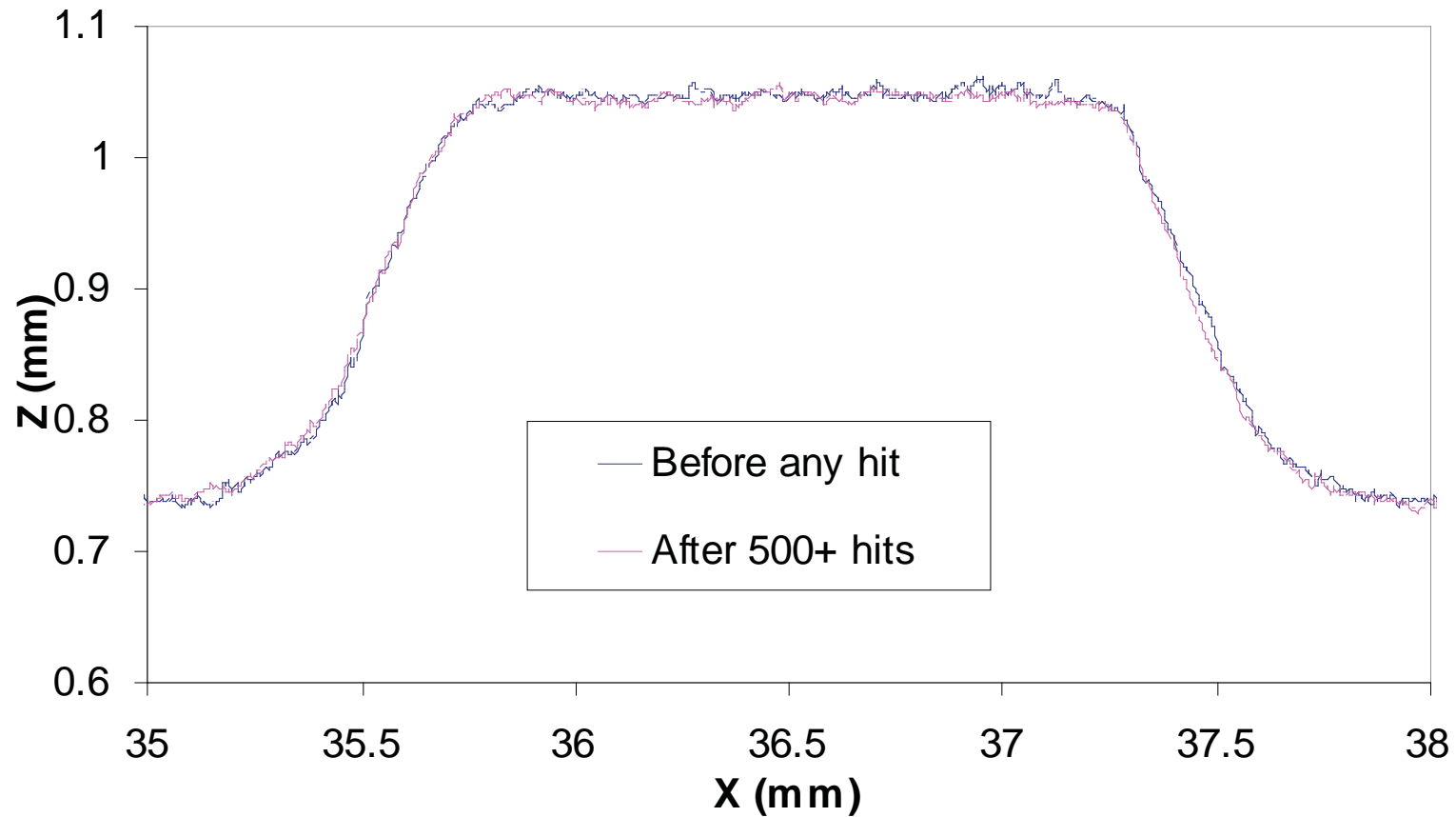

Scanning of one channel of the die (before and after 500+ hits)

Technical Challenges of Electromagnetic Forming Commercialization

Further investigations needed for the following challenges

- Thermal management of coil and driver plate
- Coil life (higher energy, more hits)
- Die wear (higher energy, more hits)
- Compliant layer life
- Improvement of micro-channel depth and geometry control
- Scaling up of the process for full scale fuel cell plate manufacturing
-

Summary

- A coil-to-coil electromagnetic forming machine was successfully developed to run 5-second cycle times, demonstrating the process is commercially viable and much more cost effective than conventional forming methods;
- The preliminary results are encouraging--- *87% of target channel depth was reached at 9 kJ using the compliant layer approach;*
- The velocity of the compliant layer approach was measured and simulated. Simulation results closely matched with physical measurements;
- Coil durability is good--- *Only 0.24mm deflection was detected for over 500 hits;*
- Die wear is good--- *No die wear was detected for over 500 hits;*
- Further development is required to verify the scaled up process and to improve thermal management techniques;